

EPS series



Slewing drives

rossi.com



Contents

1	Features & Benefits	4
2	Designation	6
3	Selection & verification	8
4	Data and performance summary - Main dimensions	12
5	Splined shaft ends & Loose pinions	32
6	Support overview	35
7	Parking brakes	38
8	Motor adapters	42
9	Installation & Lubrication	49
10	Gear selection data sheet	54
I	Rossi for You	56
II	Global presence, Local service	58
III	Product range	60

Slew drive gear reducers, ranging from 9 kNm to 400 kNm Maximum Output Torque over 10 primary sizes and 3 output reinforced support configurations:

- R: dual pilot flanged
- S: dual pilot compact
- H: single pilot front flanged

From nominal ratio 12,5 to 2 800

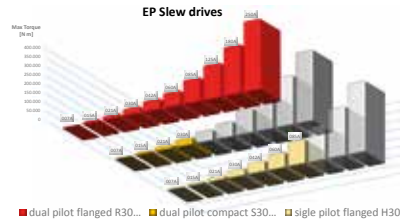

- **Wide choice of the drives allows always highest performances along with cost effective solutions**

IEC and NEMA electric motor adapter and primary hydraulic motor adapter

Further option not included in the catalog:

- In line EL and bevel EB configuration
- 5 stages in line and bevel
- Torque limiter MLA on electric motor configuration
- 4 additional standard sizes: 004A-006A-009A-012A-018A

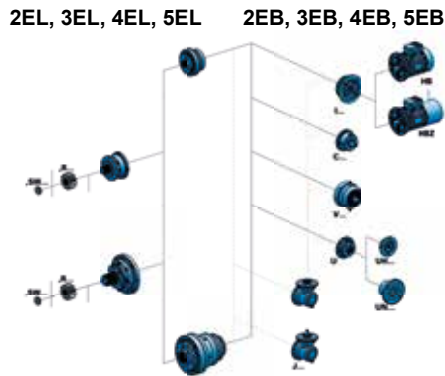

- **Wide range of Motor adapter IEC Nema or Hydraulic for global players**
- **Enable to benefit of the wider range of options of the EP industrial catalog**

Double seal and labyrinth options

Eccentricity

Heavy duty bearing

Improved lubrication system

Multiple lubrication ports at 90° angle, two greasers at opposite site

Output pinion involute profile and helix modification manufactured to the actual operating load conditions

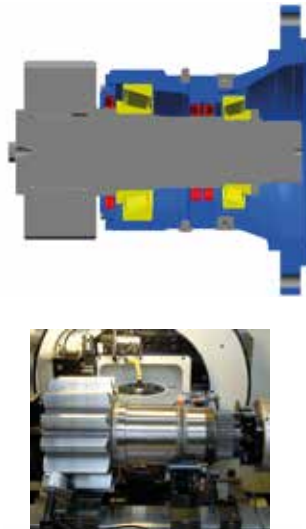

- **Enhanced seal life**
- **High precision and reduced shock loads**
- **Maximum load capacity**
Easy maintenance
- **Oil and grease ports always easy to reach, possibility to install oil and temperature probes**
- **Improvement in contact patterns and nominal rating, achieving an optimal ring gear-pinion engagement**

Four planets built-in final stage

Ground gears

Modular design concept



- **Lower backlash**
- **Enhanced Stiffness**
- **Over 16 months maintenance intervals with PAO oils**
- **Delivery flexibility and reliability**
- **Prompt service worldwide**

Rossi IEC electrical brake motors wound and set for the specific application
 Anti-sticking design of the parking brake motor
 Braking torque adjustment

Hydraulic parking brakes ranging from 75 Nm to 4250 Nm static torque over 3 main sizes

Hydraulic brakes PB

Multiple lubrication ports at 90° angle, two greaser at opposite site

Enhanced lubrication system

Possibility to install a pre-reduction stage

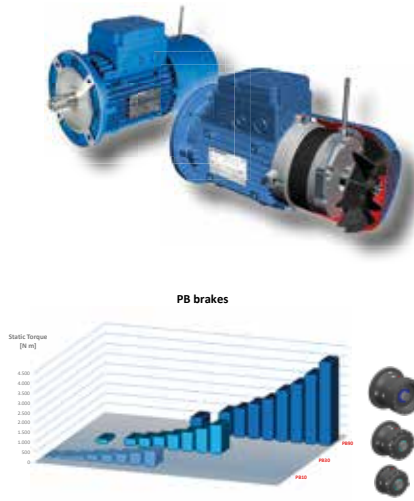

- Optimized slew drives for application and for multi-drive systems taking advantage from the European made wide range of electric motor
- Wide range of hydraulic brakes for a fine tuned application and cost effectiveness
- Oil and grease ports always easy to reach, possibility to install oil and temperature probes
- To allow higher thermal capability
- Enhanced thermal capability for continuous duty at high speed

Standard C3 coating ISO 12944, up to C5M class paint on request

Product/Parts certification

F.E.M. 1.001 L2-T5-M5 ratings with different input/output speed

ATEX directive 2014/34/EU

System certifications

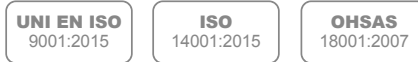

Product certifications









- Out-door environment ready marine paints
- On request, customized solution in compliance with regulations and standards of the marine, oil and gas, or other Regulations
- Easy selection according to class of mechanism
- On request, suitable to be specified for offshore platforms, petrochemical plants, mines, and flour mills, and other potentially explosive atmosphere application



- Global service
- 3 year warranty



- Direct worldwide sales and service network
- The reliability of a quality product engineered to last
- 3 year warranty since 1997

Gear reducer size and ratio

R	3EL	021	A	61,3	Y
Machine	Train of gears PLANETARY	Size	Stage composition	Transmission ratio	Type of ratio
<p>2EL 2 stages in line</p> 	<p>2EB 1 planet. and 1 bevel stage</p> 	<p>007</p> <p>...</p> <p>...</p>	<p>A catalog stage composition</p> <p>X stage composition other than catalog</p>	<p>12,4</p> <p>...</p> <p>...</p>	<p>Y catalog ratio</p> <p>Z ratio composition other than catalog</p>
<p>3EL 3 stages in line</p> 	<p>3EB 2 planet. stages and 1 bevel stage</p> 	<p>021</p> <p>...</p> <p>250</p>		<p>61,3</p> <p>...</p> <p>2800</p>	
<p>4EL 4 stages in line</p> 	<p>4EB 3 planet. stages and 1 bevel stage</p> 				

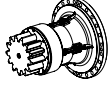
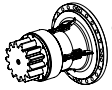
Output										Brake		Input				
R	12	14	a	Pinion data												
				Module	Teeth	Model	R	30	d			I	38x300	V1	,...	
S	100	M	1									PB10-0340	UH	SA1	V1	,...
Shaft end type	Output shaft dimensions			Type	Output model		Brake model	Braking torque	Input	Shaft / Coupling dimensions	Mounting position	Accessories				
	Shaft end	System units	Model		Model	Coupling dims.										
 S splined	058	M	1	R	10	a	PB10	0075	I...	B5	,SW...	 stop washer  ,R... pinion gear				
	...	Metric systems unit	...	double pilot extended output support, with flange	20	...	PB30	...	IEC electric motor adapter	B51						
	100	I	9	 S double pilot extended output support, without flange	...	z	PB90	0340	C...	V1						
	...	Imperial systems unit	...					4250	cylindrical shaft end	...						
 R integral pinion	240			a					V...							
	...			double pilot extended output support, without flange					cylindrical with fan							
	8		11	b					J...							
	...			front fixing flange output support					bevel shaft end							
	20		24	c					U...							
	...								universal adapter							
									UN...							
									NEMA electric motor adapter							
									UH...							
									hydraulic motor adapter							

Quick selection:

Output torques and radial loads according to F.E.M. (1.001 3rd edition – Revised 1998.10.01)
Load classification L2-T5-M5 ($n_2=15 \text{ min}^{-1}$)

Table 1

Size	$M_{N_2 \text{ FEM}}$ N m	$M_2 \text{ max}$ N m	Output						H mm
			Sxxx Rxxx		Sxxx Sxxx		Sxxx Hxxx		
			$F_{r_2 \text{ FEM}}$ N	$F_{r_2 \text{ stat}}$ N	$F_{r_2 \text{ FEM}}$ N	$F_{r_2 \text{ stat}}$ N	$F_{r_2 \text{ FEM}}$ N	$F_{r_2 \text{ stat}}$ N	
007A	7 500	9 000	126 400	180 000	126 400	180 000	126 400	180 000	45
015A	17 000	20 000	189 400	265 000	189 400	265 000	172 700	236 000	45
021A	21 200	28 000	363 900	425 000	363 900	425 000	363 900	425 000	55
030A	35 500	47 500	412 900	500 000	412 900	500 000	412 900	500 000	65
042A	50 000	67 000	435 900	560 000	435 900	560 000	435 900	560 000	65
060A	71 000	95 000	633 900	800 000	633 900	800 000	633 900	800 000	75
085A	112 000	150 000	735 800	1 060 000	735 800	1 060 000	735 800	1 060 000	85
125A	160 000	212 000	973 500	1 400 000	973 500	1 400 000	973 500	1 400 000	100
180A	224 000	300 000	1 073 400	1 600 000	1 073 400	1 600 000	1 073 400	1 600 000	120
250A	315 000	425 000	1 293 600	2 000 000	1 293 600	2 000 000	1 293 600	2 000 000	130

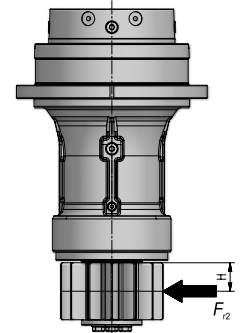

- $M_{N_2 \text{ FEM}}$ [Nm] is the nominal output torque related to a given load classification and output speed. In the table it is shown the maximum value for each gearbox size, see the following pages for the actual values for every reduction ratio.
- $M_2 \text{ max}$ [Nm] is the maximum torque admissible on gear reducer low speed shaft. In the table it is shown the maximum value for each gearbox size, see the following pages for the actual values for every reduction ratio.
- $F_{r_2 \text{ FEM}}$ [N] is the radial load admissible for a given load classification and point of application on the low speed shaft.s
- $F_{r_2 \text{ stat}}$ [N] is the maximum static radial load admissible for a given point of application on the low speed shaft.

Application factors KA and mechanism groups

For load classification different from L2-T5-M5 the gearbox selection can be based on the application factor obtained from the following Table 2.
See formula a) at page 14.

Table 2

Class of load spectrum	Class of utilization						
	T2 400h<T2≤800h	T3 800h<T3≤1600h	T4 1600h<T4≤3200h	T5 3200h<T5≤6300h	T6 6300h<T6≤12500h	T7 12500h<T7≤25000h	T8 25000h<T8≤50000h
L1 $0 < k_m \leq 0,125$	M1 0,80	M2 0,85	M3 0,90	M4 0,95	M5 1,00	M6 1,06	M7 1,18
L2 $0,125 < k_m \leq 0,250$	M2 0,85	M3 0,90	M4 0,95	M5 1,00	M6 1,06	M7 1,18	M8 1,40
L3 $0,25 < k_m \leq 0,5$	M3 0,95	M4 1,00	M5 1,06	M6 1,12	M7 1,25	M8 1,40	M8 1,60
L4 $0,5 < k_m \leq 1$	M4 1,06	M5 1,12	M6 1,18	M7 1,32	M8 1,50	M8 1,60	M8 1,80

Load spectra (examples)

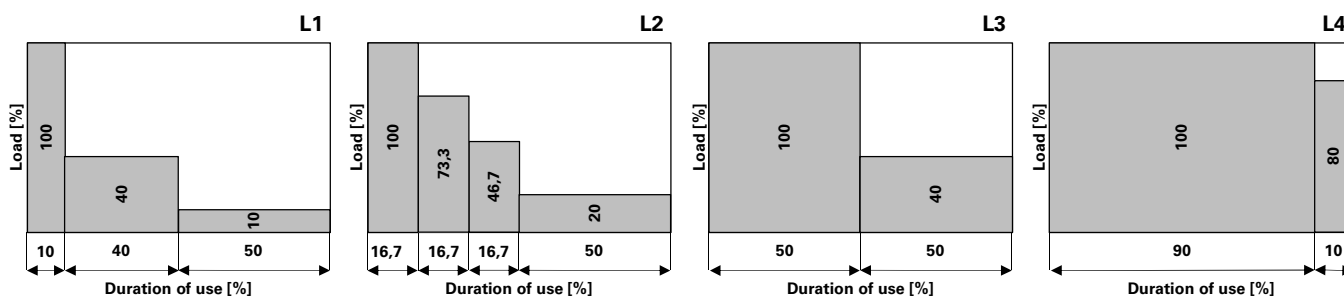

Group classification guidance

Type of appliance Designation	Particulars concerning nature of use	Type of mechanism				
		Slewing	Hoisting	Luffing	Travers	Travel
Erection cranes	-	M2-M3	M2-M3	M1-M2	M1-M2	M2-M3
Stocking and reclaiming transporter	Hook duty	M4	M5-M6	-	M4-M5	M5-M6
Stocking and reclaiming transporter	Grab or magnet	M6	M7-M8	-	M6-M7	M7-M8
Workshop cranes	-	M4	M6	-	M4	M5
Overhead travelling cranes, pigbreaking cranes, scrapyard cranes	Grab or magnet	M6	M8	-	M6-M7	M7-M8
Bridge cranes for unloading, bridge cranes for containers	a) Hook or spreaded duty	M5-M6	M6-M7	M3-M4	M6-M7	M4-M5
Other bridge cranes (with crab and/or slewing jib crane)	b) Hook duty	M4-M5	M4-M5	-	M4-M5	M4-M5
Bridge cranes for unloading, bridge cranes (with crab and/or slewing jib crane)	Grab or magnet	M5-M6	M8	M3-M4	M7-M8	M4-M5
Drydock cranes, shipyard jib cranes, jib cranes for dismantling	Hook duty	M4-M5	M5-M6	M4-M5	M4-M5	M5-M6
Dockside cranes (slewing, on gantry, etc.), floating cranes and pontoon derricks	Hook duty	M5-M6	M6-M7	M5-M6	-	M3-M4
Dockside cranes (slewing, on gantry, etc.), floating cranes and pontoon derricks	-	M6-M7	M7-M8	M6-M7	-	M4-M5
Floating cranes and pontoon derricks for very heavy loads (usually greater than 100t)	-	M3-M4	M3-M4	M3-M4	-	-
Deck cranes	Hook duty	M3-M4	M4	M3-M4	M2	M3
Deck cranes	Grab or magnet	M3-M4	M5-M6	M3-M4	M4-M5	M3-M4
Tower cranes for building	-	M5	M5	M4	M3	M3
Derricks	-	M1-M2	M2-M3	M1-M2	-	-
Railway cranes allowed to run in train	-	M2-M3	M3-M4	M2-M3	-	-
Mobile cranes	Hook	M2-M3	M3-M4	M2-M3	-	-

Selection according to F.E.M. (1.001 3rd edition – Revised 1998.10.01)¹⁾

Required application data

- Class of load spectrum L1 ... L4
- Class of utilization T2 ... T8
- Running conditions: accelerations-decelerations, frictional forces, wind effect.
- External drive data: pinion and ring gear module, number of teeth and pressure angle.
- Gear reducer input speed (depending on motor type) and output speed required.

Required torque

Starting from running conditions (accelerations-decelerations, frictional forces, wind effect) and load spectrum determine the maximum load:

$$S_M = \max (S_{M \max I}; S_{M \max II})$$

where:

$$S_{M \max I} = (S_{MF} + S_{MA}) \cdot \gamma_m$$

is the maximum torque (combination of the most unfavourable actual values) during normal service without wind

$$S_{M \max II} = (S_{MF} + S_{MA} + S_{MW8}) \cdot \gamma_m$$

$$S_{M \max II} = (S_{MF} + S_{MW25}) \cdot \gamma_m$$

is the maximum of the two torque values (each one as a combination of the most unfavourable actual values) during normal service with wind, where:

- S_{MF} [N m] is mean torque generated by friction;
- S_{MA} [N m] is mean torque generated by acceleration or deceleration;
- S_{MW8} [N m] is mean torque corresponding to a 80 N/m² wind;
- S_{MW25} [N m] is mean torque corresponding to a 250 N/m² wind;
- γ_m load amplification factor depending on mechanism group according to the following table:

Load amplification factor	Mechanism group							
	M1	M2	M3	M4	M5	M6	M7	M8
γ_m	1	1,04	1,08	1,12	1,16	1,2	1,25	1,3

Determine the gear reducer required output torque, as follows:

$$M_{2 \text{ required}} = S_M / (i_e \cdot \eta_e)$$

where:

- i_e is the external drive gear ratio (given by z_2 / z_1 , being z_1 and z_2 the number of teeth of the pinion and of the ring gear respectively)
- η_e is the the external drive efficiency (approx. 0,85)

1) For complete selection please refer to FEM section I 3rd edition.

Gear reducer size and transmission ratio selection

- Verify that the calculation of the M_2 required torque at gearbox shaft has been made taking in account the amplication factor.

Choose in the selection tables a gear reducer in terms of size, train of gears and transmission ratio i at the same time, such as:

$$M_{N2 \text{ FEM}} / K_A \geq M_{2 \text{ required}} \quad \text{a)}$$

$$i \geq i_{\text{required}}$$

where:

- $M_{N2 \text{ FEM}}$ [N m] is the gear reducer nominal torque referred to FEM load spectrum class L_2 and utilization class T5;
- K_A is the application factor to convert the gear reducer nominal torque according to the actual class of utilization and load spectrum, see Table 2;

- Verify that $M_{N2 \text{ FEM}} / K_A \leq M_{N2 \text{ FEM max}}$, if not $M_{N2 \text{ FEM max}}$ should be used in the above formula a)
- The value of $M_{N2 \text{ FEM max}}$ for each gearbox size and ratio is shown at ch. 4 Data and performance summary.

- i_{required} is the gear reducer required transmission ratio (n_1 / n_2);
- n_1 [min⁻¹] is the maximum gear reducer input speed (depending on motor type; eg.: for a IEC 4 poles motor, $n_1 = 1\,400 \text{ min}^{-1}$);
- n_2 [min⁻¹] is the maximum speed required at the gear reducer low speed shaft.

Radial load verifications

Verify that the radial load on the gear reducer output pinion shaft is less than the reference value $F_{r2\text{FEM}}$ for the chosen gear reducer

$$\frac{M_{2\text{ required}} \cdot K_A \cdot 2000}{D_p \cdot \cos\alpha} \leq F_{r2\text{ FEM}}$$

where:

- D_p [mm] is the pinion pitch diameter;
- α [rad] is the pinion tooth pressure angle;
- $F_{r2\text{ FEM}}$ [N] is the permissible radial load (for L2 T5, $n_2 = 15 \text{ min}^{-1}$) acting in the middle of the pinion facewidth and without axial load.

Dynamic overloads

Overloads are normally generated when:

- starting or braking on full load (especially for high inertias and low transmission ratios);
- the low speed shaft becomes driving member due to driven machine inertia;
- the applied motor power is higher than required;
- other static or dynamic causes occur.

The maximum peak torque caused by overloads must be lower than $M_{2\text{max}}$.

Starting torque verifications:

$$M_{2\text{ start}} = \left(\frac{M_{\text{start}}}{M_N} \cdot M_{2\text{ available}} - M_{2\text{ required}} \right) \cdot \frac{J}{J+J_0} + M_{2\text{ required}} \leq M_{2\text{max}}$$

where:

- $M_{2\text{ required}}$ [N m] is the torque absorbed by the machine through work and frictions
- $M_{2\text{ available}}$ [N m] is the output torque due to the motor's nominal power;
- M_{start} / M_N is the ratio of motor peak;
- J_0 [kg m²] is the moment of inertia (of mass) of the motor;
- J [kg m²] is the external moment of inertia (of mass) for gear reducer, coupling, driven machine referred to the motor shaft;

NOTE: when seeking to verify that starting torque is sufficiently high for starting, take into account starting friction, if any, in evaluating $M_{2\text{ required}}$.

Stopping machines with high kinetic energy (high moments of inertia combined with high speeds) with brake motor:

$$M_{2\text{ brake}} = \left(\frac{M_f}{\eta} \cdot i + M_{2\text{ required}} \right) \cdot \frac{J}{J+J_0} - M_{2\text{ required}} \leq M_{2\text{max}}$$

where:

- M_f [N m] is the braking torque at the gear reducer input shaft;
- η is the gear reducer efficiency.

Efficiency	Train of gears		
	2EL	3EL	4EL
η	0,94	0,91	0,89

Static load verifications

Verify that static braking torque and static overhung load (referred to the gear reducer low speed shaft) are lower than the values admitted by the gear reducer:

$$M_f \cdot i / \eta \leq M_{2\text{ max}} \quad \frac{M_f \cdot i \cdot 2000}{\eta \cdot D_p \cdot \cos\alpha} \leq F_{r2\text{ stat}}$$

Angular backlash

A rough guide for the angular backlash $\Delta\phi$ (high speed shaft being locked) is given in the table.

On request, gear reducers with **reduced backlash** are available.

Size	Pinion fitted on output shaft		One piece pinion-shaft	
	$\Delta\phi$ [°] Average	$\Delta\phi$ [°] Max	$\Delta\phi$ [°] Average	$\Delta\phi$ [°] Average
007A	23,7	33,9	17,6	23,9
015A	17,7	25,1	14,2	19,0
021A	15,9	22,3	12,6	16,9
030A	18,1	23,5	15,2	19,0
042A	16,6	21,4	13,9	17,3
060A	15,6	20,0	12,9	15,9
085A	13,6	16,9	11,2	13,4
125A	12,2	15,1	10,2	12,1
180A	13,3	16,1	11,2	13,1
250A	11,7	14,2	9,8	11,5

Sizes 007A

According to FEM 1.001 L2/T5/M5 conditions

	i_N	i_{eff}	$n_1 \text{ min}^{-1}$								$M_{N2 \text{ FEM max}}$ N m	M_{2max} N m	n_{1max} min ⁻¹	n_{1peak} min ⁻¹
			2 800		1 400		900		500					
			n_2 min ⁻¹	$M_{N2 \text{ FEM}}$ N m	n_2 min ⁻¹	$M_{N2 \text{ FEM}}$ N m	n_2 min ⁻¹	$M_{N2 \text{ FEM}}$ N m	n_2 min ⁻¹	$M_{N2 \text{ FEM}}$ N m				
2EL	12,5													
	14	14,7	191	5 790	95,4	6 480	61,3	6 650	34,1	6 890	7 500	9 000	2 800	3 150
	16	17,4	161	5 980	80,4	7 160	51,7	7 490	28,7	7 500	7 500	9 000	3 150	4 000
	18	18,6	150	4 980	75,2	5 350	48,3	5 610	26,9	5 960	7 100	8 500	2 800	3 150
	20													
	22,4	22,1	127	6 180	63,4	6 650	40,7	6 970	22,6	7 420	7 500	9 000	3 150	4 000
	25	25,9	108	5 310	54,0	5 710	34,7	5 970	19,3	6 350	7 290	8 580	3 150	4 000
	28	28	99,9	5 200	50,0	5 590	32,1	5 850	17,8	6 220	7 100	8 500	3 150	4 000
	31,5	31,9	87,8	4 090	43,9	4 390	28,2	4 600	15,7	4 890	6 070	7 290	3 150	4 000
	35,5	32,9	85,1	5 290	42,6	5 680	27,4	5 950	15,2	6 320	7 100	8 500	3 150	4 000
40	40,4	69,3	5 190	34,6	5 570	22,3	5 830	12,4	6 200	7 100	8 500	3 150	4 000	
45														
3EL	50	50,6	55,3	6 690	27,6	6 980	17,8	7 160	9,87	7 420	7 500	9 000	2 800	3 150
	63	61,1	45,8	6 770	22,9	7 060	14,7	7 250	8,18	7 500	7 500	9 000	3 150	4 000
	71	72,5	38,6	7 500	19,3	7 500	12,4	7 500	6,90	7 500	7 500	9 000	3 150	4 000
	80	76,2	36,7	7 050	18,4	7 500	11,8	7 500	6,56	7 500	7 500	9 000	2 800	3 150
	90	92	30,5	7 190	15,2	7 500	9,79	7 500	5,44	7 500	7 500	9 000	3 150	4 000
	100	105	26,8	6 990	13,4	7 290	8,60	7 480	4,78	7 500	7 500	9 000	3 150	4 000
	112	109	25,8	7 320	12,9	7 500	8,28	7 500	4,60	7 500	7 500	9 000	3 150	4 000
	125	124	22,6	7 500	11,3	7 500	7,25	7 500	4,03	7 500	7 500	9 000	3 150	4 000
	140	136	20,6	7 490	10,3	7 500	6,61	7 500	3,67	7 500	7 500	9 000	3 150	4 000
	160	157	17,8	7 500	8,89	7 500	5,72	7 500	3,18	7 500	7 500	9 000	3 150	4 000
	180	189	14,8	7 500	7,42	7 500	4,77	7 500	2,65	7 500	7 500	9 000	3 150	4 000
	200	203	13,8	6 380	6,91	6 840	4,44	7 090	2,47	7 100	7 100	8 500	3 150	4 000
	224	221	12,6	6 630	6,32	7 120	4,06	7 290	2,26	7 290	7 290	8 580	3 150	4 000
250	239	11,7	6 500	5,85	6 930	3,76	7 100	2,09	7 100	7 100	8 500	3 150	4 000	
4EL	180	175	16,0	7 210	8,01	7 500	5,15	7 500	2,86	7 500	7 500	9 000	2 800	3 150
	200	207	13,5	7 500	6,75	7 500	4,34	7 500	2,41	7 500	7 500	9 000	2 800	3 150
	250	250	11,2	7 500	5,60	7 500	3,60	7 500	2,00	7 500	7 500	9 000	3 150	4 000
	280	296	9,47	7 500	4,73	7 500	3,04	7 500	1,69	7 500	7 500	9 000	3 150	4 000
	315	317	8,83	7 500	4,41	7 500	2,84	7 500	1,58	7 500	7 500	9 000	3 150	4 000
	355	357	7,85	7 500	3,93	7 500	2,52	7 500	1,40	7 500	7 500	9 000	3 150	4 000
	400	422	6,64	7 500	3,32	7 500	2,13	7 500	1,19	7 500	7 500	9 000	3 150	4 000
	450	452	6,19	7 500	3,09	7 500	1,99	7 500	1,11	7 500	7 500	9 000	3 150	4 000
	500	517	5,42	7 500	2,71	7 500	1,74	7 500	0,968	7 500	7 500	9 000	3 150	4 000
	560	566	4,94	7 500	2,47	7 500	1,59	7 500	0,883	7 500	7 500	9 000	3 150	4 000
	630	611	4,58	7 500	2,29	7 500	1,47	7 500	0,819	7 500	7 500	9 000	3 150	4 000
	710	732	3,83	7 500	1,91	7 500	1,23	7 500	0,683	7 500	7 500	9 000	3 150	4 000
	800	838	3,34	7 500	1,67	7 500	1,07	7 500	0,597	7 500	7 500	9 000	3 150	4 000
	900	916	3,06	7 500	1,53	7 500	0,983	7 500	0,546	7 500	7 500	9 000	3 150	4 000
	1000	970	2,89	7 500	1,44	7 500	0,928	7 500	0,516	7 500	7 500	9 000	3 150	4 000
	1120	1122	2,50	7 500	1,25	7 500	0,802	7 500	0,446	7 500	7 500	9 000	3 150	4 000
	1250	1248	2,24	7 100	1,12	7 100	0,721	7 100	0,401	7 100	7 100	8 500	3 150	4 000
	1400	1344	2,08	7 500	1,04	7 500	0,669	7 500	0,372	7 500	7 500	9 000	3 150	4 000
	1600	1611	1,74	7 500	0,869	7 500	0,559	7 500	0,310	7 500	7 500	9 000	3 150	4 000
1800	1730	1,62	7 100	0,809	7 100	0,520	7 100	0,289	7 100	7 100	8 500	3 150	4 000	
2000	2043	1,37	7 100	0,685	7 100	0,440	7 100	0,245	7 100	7 100	8 500	3 150	4 000	
2240														
2500	2399	1,17	7 100	0,584	7 100	0,375	7 100	0,208	7 100	7 100	8 500	3 150	4 000	
2800	2947	0,950	7 100	0,475	7 100	0,305	7 100	0,170	7 100	7 100	8 500	3 150	4 000	

Sizes 007A (006A, 004A)

H - Front fixing flange output support

R - Double pilot extended output support, with flange

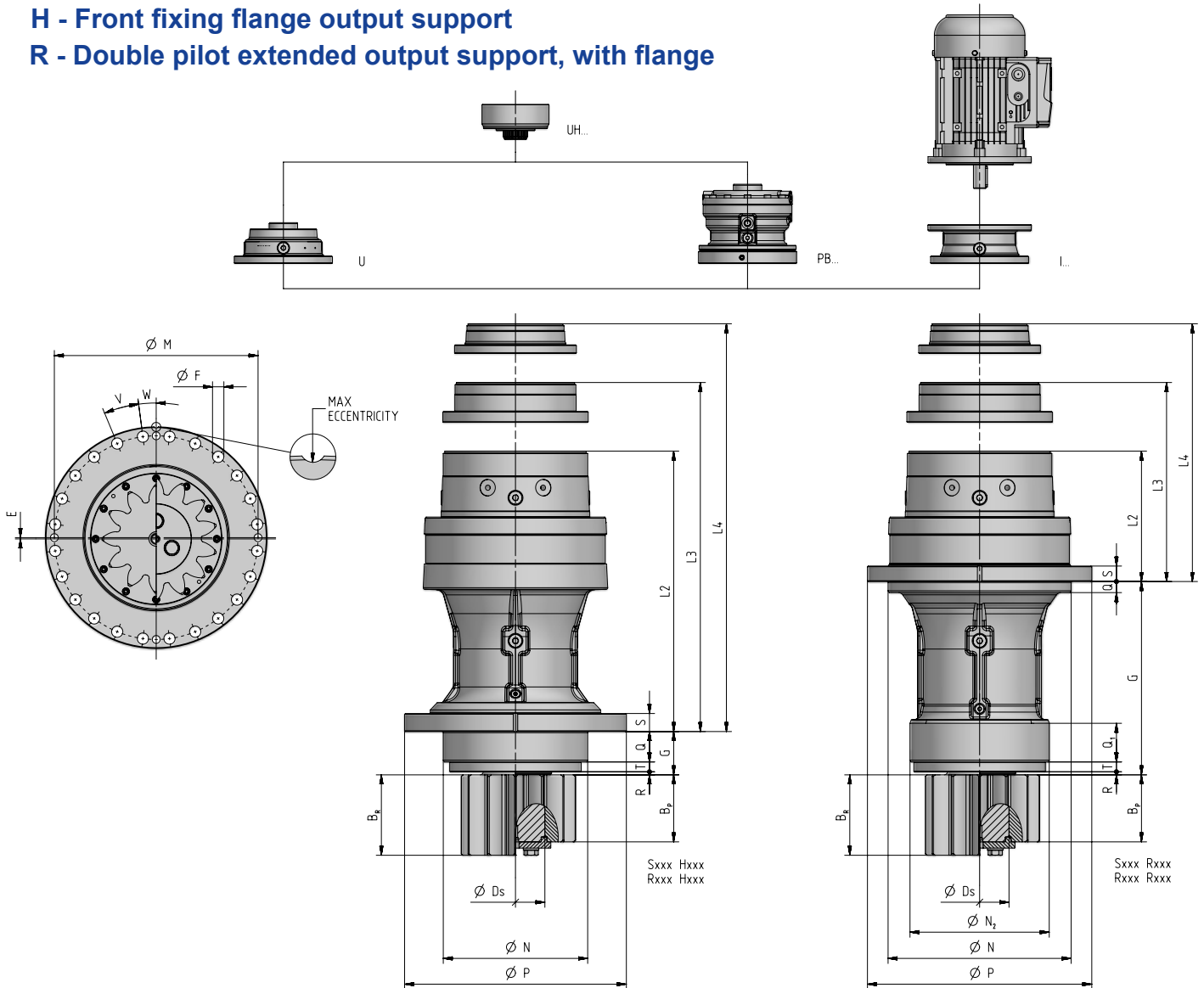

Type	X	P	N f7	N ₂ f7	G	L	Q	Q ₁	S	R	T	M	F	V	W	E	D _s DIN5482	L2	L3	L4
R30b	234	290	195	180	175	-	15	45	25	4	11	265	13	12x30°	0°	1,5	B70x64-e9	124	154	184
H30b	234	272	175	-	41	-	15	-	25	4	22	245	18	10x36°	0°	1,5	B70x64-e9	258	288	318

	Pinion code	m	z	x	B _R B _P	Output type	Material	Internal bore DIN5482
Integral pinion	R1011b	10	11	0,5	70	H-R-S	case hardened and ground steel	
	R1012a	10	12	0,5	78	H-R-S	case hardened and ground steel	
	R1013a	10	13	0,5	80	S31b	case hardened and ground steel	
Loose pinion	R003CBb	8	12	0,5	68	*	through hardened steel	A58x53-H10
	R003CCb	8	13	0,5	68	*	through hardened steel	A58x53-H10
	R003CDB	8	14	0	95	*	through hardened steel	A58x53-H10
	R003CEb	8	16	0,5	58	*	through hardened steel	A58x53-H10
	R007CJb	8	20	0,5	80	*	through hardened steel	
	R007CJc	8	20	0,5	90	*	case hardened and ground steel	A70x64-H10
	R007DBb	10	11	0,5	78	*	through hardened steel	A58x53-H10
	R006Db	10	12	0,5	68	*	case hardened and ground steel	A62x57-H10
	R007DDb	10	14	0,5	100	*	case hardened and ground steel	A70x64-H10
	R007DEb	10	15	0,5	110	*	through hardened steel	

Sizes 015A

According to FEM 1.001 L2/T5/M5 conditions

	i_n	i_{eff}	$n_1 \text{ min}^{-1}$								$M_{N2 \text{ FEM max}}$ N m	M_{2max} N m	n_{1max} min ⁻¹	n_{1peak} min ⁻¹
			2 800		1 400		900		500					
			n_2 min ⁻¹	$M_{N2 \text{ FEM}}$ N m	n_2 min ⁻¹	$M_{N2 \text{ FEM}}$ N m	n_2 min ⁻¹	$M_{N2 \text{ FEM}}$ N m	n_2 min ⁻¹	$M_{N2 \text{ FEM}}$ N m				
2EL	12,5	12,4	-	-	113	12 500	72,8	12 500	40,4	12 500	12 500	15 000	2 500	2 800
	14	14,7	-	-	95,4	14 200	61,3	14 900	34,1	15 800	17 000	20 000	2 500	2 800
	16	17,4	161	13 500	80,4	14 500	51,7	15 100	28,7	16 100	17 000	20 000	2 800	3 550
	18	18,6	-	-	75,2	10 800	48,3	11 300	26,9	12 000	13 200	16 000	2 500	2 800
	20													
	22,4	22,1	127	13 800	63,4	14 800	40,7	15 500	22,6	16 500	17 000	20 000	2 800	4 000
	25	25,9	108	14 000	54,0	15 100	34,7	15 800	19,3	16 800	17 000	20 000	2 800	4 000
	28	28	99,9	10 400	50,0	11 200	32,1	11 700	17,8	12 500	13 200	16 000	2 800	4 000
	31,5	31,9	87,8	11 400	43,9	12 200	28,2	12 800	15,7	13 600	16 200	19 200	2 800	4 000
	35,5	32,9	85,1	10 600	42,6	11 400	27,4	11 900	15,2	12 700	13 200	16 000	2 800	4 000
40	40,4	69,3	10 800	34,6	11 600	22,3	12 200	12,4	13 000	13 200	16 000	2 800	4 000	
45	44,8	62,5	11 800	31,3	11 800	20,1	11 800	11,2	11 800	11 800	14 000	2 800	4 000	
3EL	50	51,6	54,2	15 100	27,1	16 200	17,4	16 900	9,68	17 000	17 000	20 000	2 800	3 150
	63	61,3	45,7	15 300	22,8	16 500	14,7	17 000	8,16	17 000	17 000	20 000	3 150	4 000
	71	72,7	38,5	15 600	19,3	16 800	12,4	17 000	6,88	17 000	17 000	20 000	3 150	4 000
	80	77,7	36,0	15 700	18,0	16 900	11,6	17 000	6,43	17 000	17 000	20 000	3 150	4 000
	90	92,2	30,4	16 000	15,2	17 000	9,76	17 000	5,42	17 000	17 000	20 000	3 150	4 000
	100	98,6	28,4	11 900	14,2	12 800	9,13	13 200	5,07	13 200	13 200	16 000	3 150	4 000
	112	108	25,9	16 300	12,9	17 000	8,31	17 000	4,62	17 000	17 000	20 000	3 150	4 000
	125	117	23,9	16 400	12,0	17 000	7,69	17 000	4,27	17 000	17 000	20 000	3 150	4 000
	140	137	20,4	16 700	10,2	17 000	6,55	17 000	3,64	17 000	17 000	20 000	3 150	4 000
	160	169	16,6	17 000	8,30	17 000	5,33	17 000	2,96	17 000	17 000	20 000	3 150	4 000
	180	174	16,1	12 600	8,04	13 200	5,17	13 200	2,87	13 200	13 200	16 000	3 150	4 000
	200	198	14,1	17 000	7,07	17 000	4,54	17 000	2,52	17 000	17 000	20 000	3 150	4 000
224	214	13,1	12 900	6,54	13 200	4,21	13 200	2,34	13 200	13 200	16 000	3 150	4 000	
250	251	11,1	13 100	5,57	13 200	3,58	13 200	1,99	13 200	13 200	16 000	3 150	4 000	
4EL	180	178	15,7	17 000	7,86	17 000	5,05	17 000	2,81	17 000	17 000	20 000	2 800	3 150
	200	211	13,2	17 000	6,62	17 000	4,26	17 000	2,37	17 000	17 000	20 000	2 800	3 150
	250	255	11,0	17 000	5,49	17 000	3,53	17 000	1,96	17 000	17 000	20 000	3 150	4 000
	280	301	9,29	17 000	4,64	17 000	2,99	17 000	1,66	17 000	17 000	20 000	3 150	4 000
	315	323	8,66	17 000	4,33	17 000	2,78	17 000	1,55	17 000	17 000	20 000	3 150	4 000
	355	358	7,83	17 000	3,91	17 000	2,52	17 000	1,40	17 000	17 000	20 000	3 150	4 000
	400	404	6,94	17 000	3,47	17 000	2,23	17 000	1,24	17 000	17 000	20 000	2 800	3 150
	450	448	6,25	17 000	3,13	17 000	2,01	17 000	1,12	17 000	17 000	20 000	3 150	4 000
	500	518	5,40	17 000	2,70	17 000	1,74	17 000	0,965	17 000	17 000	20 000	3 150	4 000
	560	568	4,93	17 000	2,46	17 000	1,58	17 000	0,880	17 000	17 000	20 000	3 150	4 000
	630	657	4,26	17 000	2,13	17 000	1,37	17 000	0,761	17 000	17 000	20 000	3 150	4 000
	710	720	3,89	17 000	1,94	17 000	1,25	17 000	0,694	17 000	17 000	20 000	3 150	4 000
	800	788	3,56	17 000	1,78	17 000	1,14	17 000	0,635	17 000	17 000	20 000	3 150	4 000
	900	846	3,31	17 000	1,66	17 000	1,06	17 000	0,591	17 000	17 000	20 000	3 150	4 000
	1000	999	2,80	17 000	1,40	17 000	0,901	17 000	0,501	17 000	17 000	20 000	3 150	4 000
	1120	1172	2,39	17 000	1,19	17 000	0,768	17 000	0,426	17 000	17 000	20 000	3 150	4 000
	1250	1267	2,21	13 200	1,11	13 200	0,710	13 200	0,395	13 200	13 200	16 000	3 150	4 000
	1400	1441	1,94	17 000	0,972	17 000	0,625	17 000	0,347	17 000	17 000	20 000	3 150	4 000
1600	1691	1,66	17 000	0,828	17 000	0,532	17 000	0,296	17 000	17 000	20 000	3 150	4 000	
1800	1827	1,53	13 200	0,766	13 200	0,492	13 200	0,274	13 200	13 200	16 000	3 150	4 000	
2000														
2240	2145	1,31	13 200	0,653	13 200	0,420	13 200	0,233	13 200	13 200	16 000	3 150	4 000	
2500	2636	1,06	13 200	0,531	13 200	0,341	13 200	0,190	13 200	13 200	16 000	3 150	4 000	
2800	2921	0,959	11 800	0,479	11 800	0,308	11 800	0,171	11 800	11 800	14 000	3 150	4 000	

Sizes 015A (012A, 009A)

H - Front fixing flange output support

R - Double pilot extended output support, with flange

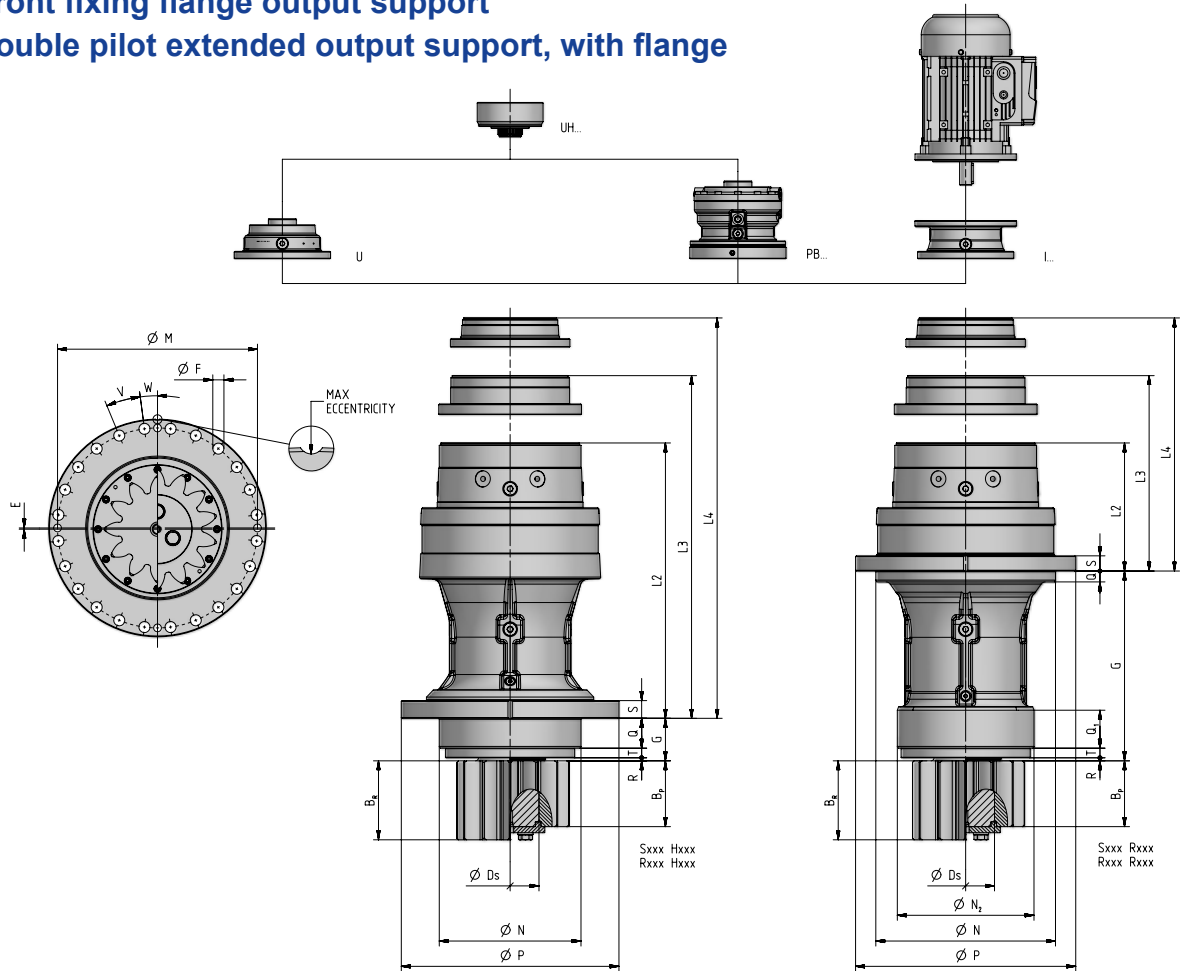

Type	X	P	N f7	N ₂ f7	G	L	Q	Q ₁	S	R	T	M	F	V	W	E	D _s DIN 5482	L2	L3	L4
R30c	282	360	250	200	230	-	13	65	25	5	12	325	17,5	10x36°	0°	2,5	B90x84-e9	171	230	260
R31c	282	360	250	200	230	-	14	65	25	5	12	325	18	12x30°	0°	2,5		171	230	260
R32c	282	350	290	184	292	-	14	50	25	11	27	325	14,5	12x30°	15°	0		171	230	260
R34c	282	360	250	200	230	-	14	65	25	5	12	325	18	12x30°	0°	1,5		171	230	260
R37c	282	350	290	184	292	-	14	50	25	11	27	325	14,5	12x30°	15°	2		171	230	260
H20c	280	280	200	-	45	-	14,5	-	20	16	25	250	17	12x30°	0°	1	B90x84-e9	336	395	425
H30c	282	280	200	-	40	-	16,5	-	20	2,5	23	250	17	12x30°	0°	1	B90x84-e9	336	395	425
R10c	280	280	200	-	45	-	14,5	-	20	16	25	250	17	12x30°	0°	1	B90x84-e9	336	395	425

	Pinion code	m	z	x	B _R B _P	Output type	Material	Internal bore DIN5482
Integral pinion	R1013a	10	13	0,5	95	R10c	case hardened and ground steel	
	R1013c	10	13	0,5	105	R32c	case hardened and ground steel	
	R1020a	10	20	0,5	95	R21c	case hardened and ground steel	
	R1211e	12	11	0,5	100	R30c	case hardened and ground steel	
	R1211c	12	11	0,5	115	R	case hardened and ground steel	
	R1211d	12	11	0,5	115	R30c	case hardened and ground steel	
	R1212c	12	12	0,5	130	R34c	case hardened and ground steel	
	R1212a	12	12	0,5	140	R31c - R34c	case hardened and ground steel	
Loose pinion	R018DEb	10	15	0,5	100	*	case hardened and ground steel	
	R018FCb	14	13	0,5	140	*	through hardened steel	
	R018FEb	14	15	0,5	105	*	case hardened and ground steel	
	R018GBb	16	12	0,5	122	*	case hardened and ground steel	
	R018GEb	16	15	0,5	122	*	case hardened and ground steel	
	R018GGb	16	17	0,5	110	*	case hardened and ground steel	
	R018Hlb	18	19	0,5	150	*	case hardened and ground steel	

* For all the output types H, R and S.

Sizes 021A

According to FEM 1.001 L2/T5/M5 conditions

	i_N	i_{eff}	$n_1 \text{ min}^{-1}$								$M_{N2 \text{ FEM max}}$ N m	M_{2max} N m	n_{1max} min ⁻¹	n_{1peak} min ⁻¹
			2 800		1 400		900		500					
			n_2 min ⁻¹	$M_{N2 \text{ FEM}}$ N m	n_2 min ⁻¹	$M_{N2 \text{ FEM}}$ N m	n_2 min ⁻¹	$M_{N2 \text{ FEM}}$ N m	n_2 min ⁻¹	$M_{N2 \text{ FEM}}$ N m				
2EL	12,5	12,4	-	-	113	15 700	72,8	16 000	40,4	16 000	16 000	20 000	2 500	2 800
	14	14,7	-	-	95,4	18 600	61,3	19 100	34,1	19 800	21 200	25 500	2 500	2 800
	16	17,4	161	18 900	80,4	20 200	51,7	21 200	28,7	21 200	21 200	28 000	2 800	3 550
	18	18,6	-	-	75,2	17 900	48,3	18 000	26,9	18 000	18 000	28 000	2 500	2 800
	20													
	22,4	22,1	127	17 700	63,4	19 000	40,7	19 900	22,6	21 200	21 200	28 000	2 800	4 000
	25	25,9	108	14 900	54,0	16 100	34,7	16 800	19,3	17 900	19 200	22 700	2 800	4 000
	28	28	99,9	17 400	50,0	18 000	32,1	18 000	17,8	18 000	18 000	28 000	2 800	4 000
	31,5													
	35,5	32,9	85,1	17 700	42,6	18 000	27,4	18 000	15,2	18 000	18 000	28 000	2 800	4 000
	40	40,4	69,3	14 500	34,6	15 500	22,3	16 200	12,4	17 200	18 000	24 400	2 800	4 000
	45	44,8	62,5	14 700	31,3	15 000	20,1	15 000	11,2	15 000	15 000	21 200	2 800	4 000
3EL	50	51,6	54,2	19 200	27,1	20 000	17,4	20 600	9,68	21 200	21 200	25 500	2 800	3 150
	63	61,3	45,7	21 200	22,8	21 200	14,7	21 200	8,16	21 200	21 200	28 000	2 800	3 150
	71	72,7	38,5	21 200	19,3	21 200	12,4	21 200	6,88	21 200	21 200	28 000	3 150	4 000
	80	77,7	36,0	20 200	18,0	21 200	11,6	21 200	6,43	21 200	21 200	28 000	2 800	3 150
	90	92,2	30,4	20 500	15,2	21 200	9,76	21 200	5,42	21 200	21 200	28 000	3 150	4 000
	100	98,6	28,4	18 000	14,2	18 000	9,13	18 000	5,07	18 000	18 000	28 000	3 150	4 000
	112	108	25,9	21 200	12,9	21 200	8,31	21 200	4,62	21 200	21 200	28 000	3 150	4 000
	125	117	23,9	21 000	12,0	21 200	7,69	21 200	4,27	21 200	21 200	28 000	3 150	4 000
	140	137	20,4	21 200	10,2	21 200	6,55	21 200	3,64	21 200	21 200	28 000	3 150	4 000
	160	169	16,6	21 000	8,30	21 200	5,33	21 200	2,96	21 200	21 200	28 000	3 150	4 000
	180	174	16,1	18 000	8,04	18 000	5,17	18 000	2,87	18 000	18 000	28 000	3 150	4 000
	200	204	13,7	18 000	6,85	18 000	4,40	18 000	2,45	18 000	18 000	28 000	3 150	4 000
	224	214	13,1	18 000	6,54	18 000	4,21	18 000	2,34	18 000	18 000	28 000	3 150	4 000
	250	251	11,1	18 000	5,57	18 000	3,58	18 000	1,99	18 000	18 000	28 000	3 150	4 000
4EL	180	178	15,7	20 700	7,86	21 200	5,05	21 200	2,81	21 200	21 200	25 500	2 800	3 150
	200	211	13,2	21 200	6,62	21 200	4,26	21 200	2,37	21 200	21 200	28 000	2 800	3 150
	250	255	11,0	21 200	5,49	21 200	3,53	21 200	1,96	21 200	21 200	28 000	3 150	4 000
	280	303	9,25	21 200	4,63	21 200	2,97	21 200	1,65	21 200	21 200	28 000	3 150	4 000
	315	318	8,80	21 200	4,40	21 200	2,83	21 200	1,57	21 200	21 200	28 000	2 800	3 150
	355	358	7,83	21 200	3,91	21 200	2,52	21 200	1,40	21 200	21 200	28 000	3 150	4 000
	400	404	6,94	21 200	3,47	21 200	2,23	21 200	1,24	21 200	21 200	28 000	2 800	3 150
	450	448	6,25	21 200	3,13	21 200	2,01	21 200	1,12	21 200	21 200	28 000	3 150	4 000
	500	518	5,40	21 200	2,70	21 200	1,74	21 200	0,965	21 200	21 200	28 000	3 150	4 000
	560	568	4,93	21 200	2,46	21 200	1,58	21 200	0,880	21 200	21 200	28 000	3 150	4 000
	630	657	4,26	21 200	2,13	21 200	1,37	21 200	0,761	21 200	21 200	28 000	3 150	4 000
	710	720	3,89	21 200	1,94	21 200	1,25	21 200	0,694	21 200	21 200	28 000	3 150	4 000
	800	788	3,56	21 200	1,78	21 200	1,14	21 200	0,635	21 200	21 200	28 000	3 150	4 000
	900	846	3,31	21 200	1,66	21 200	1,06	21 200	0,591	21 200	21 200	28 000	3 150	4 000
	1000	999	2,80	21 200	1,40	21 200	0,901	21 200	0,501	21 200	21 200	28 000	3 150	4 000
	1120	1172	2,39	21 200	1,19	21 200	0,768	21 200	0,426	21 200	21 200	28 000	3 150	4 000
	1250	1267	2,21	18 000	1,11	18 000	0,710	18 000	0,395	18 000	18 000	28 000	3 150	4 000
	1400	1318	2,12	18 000	1,06	18 000	0,683	18 000	0,379	18 000	18 000	28 000	3 150	4 000
	1600	1525	1,84	18 000	0,918	18 000	0,590	18 000	0,328	18 000	18 000	28 000	3 150	4 000
	1800	1827	1,53	18 000	0,766	18 000	0,492	18 000	0,274	18 000	18 000	28 000	3 150	4 000
2000														
2240	2145	1,31	18 000	0,653	18 000	0,420	18 000	0,233	18 000	18 000	28 000	3 150	4 000	
2500	2377	1,18	15 000	0,589	15 000	0,379	15 000	0,210	15 000	15 000	21 200	3 150	4 000	
2800														

Sizes 021A (018A)

H - Front fixing flange output support

R - Double pilot extended output support, with flange

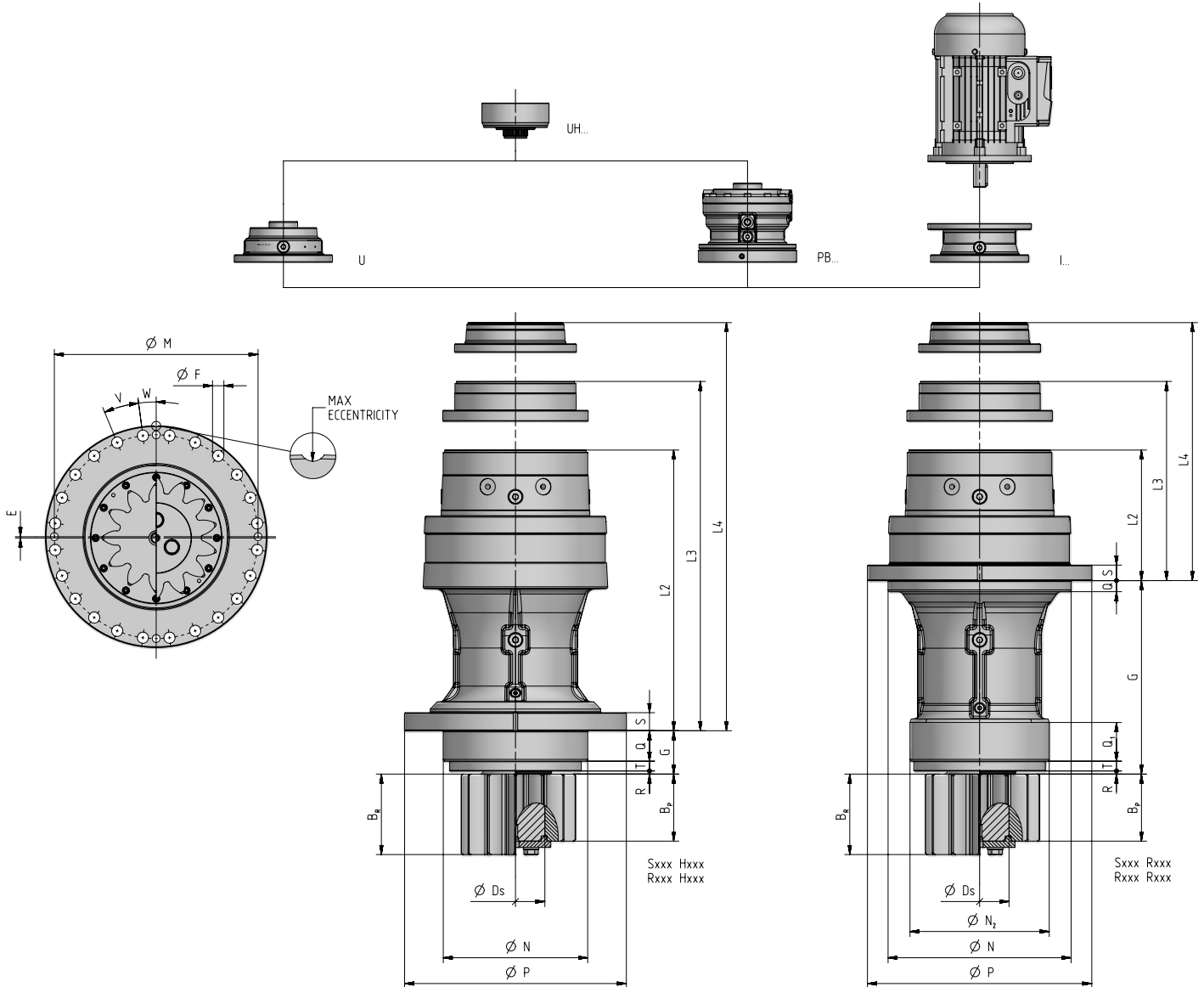

Type	X	P	N f7	N ₂ f7	G	L	Q	Q ₁	S	R	T	M	F	V	W	E	D _s DIN5482	L2	L3	L4
R30d	330	420	280	250	300	-	18	70	30	5	13	380	17,5	24x15°	7,5°	2,5	B100x94-e9	175	234	264
H30d	330	400	310	-	80	-	18	-	30	5	57	360	22	12x30°	15°	2,5	B100x94-e9	395	454	484
H33d	330	325	255 h7	-	78	-	20	-	35	5	53	295	16,5	24x15°	0°	1,5		395	454	484

	Pinion code	m	z	x	B _R B _P	Output type	Material	Internal bore DIN5482
Integral pinion	R1016a	10	16	0,5	100	S11d	case hardened and ground steel	
	R1212b	12	12	0,5	115	H-R-S	case hardened and ground steel	
	R1213b	12	13	0,5	110	S10d	case hardened and ground steel	
	R1214b	12	14	0,5	140	H-R-S	case hardened and ground steel	
	R1412a	14	12	0,5	105	S11d	case hardened and ground steel	
Loose pinion	R030CFb	8	16	0,5	95	*	through hardened steel	A90x84 A90x84
	R018DJb	10	20	0,5	90	*	through hardened steel	
	R018EFb	12	16	0,5	100	*	case hardened and ground steel	
	R030HGb	18	17	0,5	100	*	case hardened and ground steel	
	R030Hlb	18	19	0,5	135	*	case hardened and ground steel	

* For all the output types H, R and S.

Size 030A

According to FEM 1.001 L2/T5/M5 conditions

	i_n	i_{eff}	$n_1 \text{ min}^{-1}$								M_{2max} N m	n_{1max} min ⁻¹	n_{1peak} min ⁻¹	
			2 800		1 400		900		500					
			n_2 min ⁻¹	$M_{N2 FEM}$ N m	n_2 min ⁻¹	$M_{N2 FEM}$ N m	n_2 min ⁻¹	$M_{N2 FEM}$ N m	n_2 min ⁻¹	$M_{N2 FE}^{M_{N2 FEM max}}$ N m	M_{2max} N m	n_{1max} min ⁻¹	n_{1peak} min ⁻¹	
2EL	12,5													
	14	14,4	-	-	97,3	29 800	62,5	31 200	34,7	33 100	35 500	47 500	2 240	2 800
	16	17,1	-	-	82,0	30 300	52,7	31 700	29,3	33 700	35 500	47 500	2 240	3 150
	18	18,5	-	-	75,8	24 500	48,7	25 700	27,1	27 300	33 500	45 000	2 240	2 800
	20													
	22,4	21,7	-	-	64,6	31 000	41,6	32 500	23,1	34 500	35 500	47 500	2 240	3 550
	25	25,4	-	-	55,1	31 600	35,4	33 000	19,7	35 100	35 500	44 400	2 240	3 550
	28	27,8	-	-	50,4	25 600	32,4	26 800	18,0	28 400	33 500	45 000	2 240	3 550
	31,5	31,2	-	-	44,8	25 100	28,8	26 200	16,0	27 800	31 700	37 700	2 240	3 550
	35,5	32,6	-	-	42,9	26 000	27,6	27 200	15,3	28 900	33 500	45 000	2 240	3 550
	40	40,1	-	-	34,9	26 600	22,4	27 800	12,5	29 500	33 500	45 000	2 240	3 550
45														
3EL	50	50,6	-	-	27,7	33 900	17,8	35 400	9,88	35 500	35 500	47 500	2 500	2 800
	63	60,1	-	-	23,3	34 500	15,0	35 500	8,33	35 500	35 500	47 500	2 500	2 800
	71	71,3	39,3	32 700	19,6	35 100	12,6	35 500	7,02	35 500	35 500	47 500	2 800	3 550
	80	76,2	36,8	32 900	18,4	35 300	11,8	35 500	6,56	35 500	35 500	47 500	2 800	4 000
	90	90,4	31,0	33 500	15,5	35 500	9,96	35 500	5,53	35 500	35 500	47 500	2 800	4 000
	100	106	26,4	34 000	13,2	35 500	8,48	35 500	4,71	35 500	35 500	47 500	2 800	4 000
	112	115	24,4	34 300	12,2	35 500	7,85	35 500	4,36	35 500	35 500	47 500	2 800	4 000
	125	130	21,5	27 600	10,7	29 700	6,90	31 100	3,83	33 100	35 500	47 500	2 800	4 000
	140	135	20,8	34 900	10,4	35 500	6,69	35 500	3,72	35 500	35 500	47 500	2 800	4 000
	160	165	16,9	35 000	8,47	35 500	5,44	35 500	3,02	35 500	35 500	47 500	2 800	4 000
	180	173	16,2	28 700	8,11	30 800	5,21	31 900	2,89	33 400	33 500	45 000	2 800	4 000
	200	203	13,8	29 200	6,91	31 200	4,44	32 300	2,47	33 500	33 500	45 000	2 800	4 000
	224	212	13,2	29 300	6,60	31 400	4,24	32 400	2,36	33 500	33 500	45 000	2 800	4 000
250	249	11,2	29 800	5,62	31 700	3,61	32 800	2,01	33 500	33 500	45 000	2 800	4 000	
4EL	180	178	15,7	35 500	7,87	35 500	5,06	35 500	2,81	35 500	35 500	47 500	2 800	3 150
	200	211	13,3	35 500	6,63	35 500	4,26	35 500	2,37	35 500	35 500	47 500	2 800	3 150
	250	251	11,2	35 500	5,58	35 500	3,59	35 500	1,99	35 500	35 500	47 500	3 150	4 000
	280	297	9,41	35 500	4,71	35 500	3,03	35 500	1,68	35 500	35 500	47 500	3 150	4 000
	315	318	8,81	35 500	4,40	35 500	2,83	35 500	1,57	35 500	35 500	47 500	3 150	4 000
	355	344	8,14	30 800	4,07	32 500	2,62	33 500	1,45	33 500	33 500	45 000	3 150	4 000
	400	377	7,42	35 500	3,71	35 500	2,39	35 500	1,33	35 500	35 500	47 500	3 150	4 000
	450	443	6,32	35 500	3,16	35 500	2,03	35 500	1,13	35 500	35 500	47 500	3 150	4 000
	500	479	5,85	35 500	2,93	35 500	1,88	35 500	1,04	35 500	35 500	47 500	3 150	4 000
	560	562	4,98	35 500	2,49	35 500	1,60	35 500	0,890	35 500	35 500	47 500	3 150	4 000
	630	659	4,25	35 500	2,12	35 500	1,36	35 500	0,758	35 500	35 500	47 500	3 150	4 000
	710	713	3,93	35 500	1,96	35 500	1,26	35 500	0,702	35 500	35 500	47 500	3 150	4 000
	800	836	3,35	35 500	1,67	35 500	1,08	35 500	0,598	35 500	35 500	47 500	3 150	4 000
	900	876	3,20	35 500	1,60	35 500	1,03	35 500	0,571	35 500	35 500	47 500	3 150	4 000
	1000	1028	2,72	35 500	1,36	35 500	0,876	35 500	0,486	35 500	35 500	47 500	3 150	4 000
	1120	1206	2,32	35 500	1,16	35 500	0,746	35 500	0,414	35 500	35 500	44 400	3 150	4 000
	1250	1263	2,22	35 500	1,11	35 500	0,713	35 500	0,396	35 500	35 500	47 500	3 150	4 000
	1400	1482	1,89	35 500	0,944	35 500	0,607	35 500	0,337	35 500	35 500	44 400	3 150	4 000
	1600	1621	1,73	33 500	0,864	33 500	0,555	33 500	0,308	33 500	33 500	45 000	3 150	4 000
	1800													
2000	1902	1,47	33 500	0,736	33 500	0,473	33 500	0,263	33 500	33 500	45 000	3 150	4 000	
2240	2338	1,20	33 500	0,599	33 500	0,385	33 500	0,214	33 500	33 500	45 000	3 150	4 000	
2500														
2800														

Size 030A

H - Front fixing flange output support

R - Double pilot extended output support, with flange

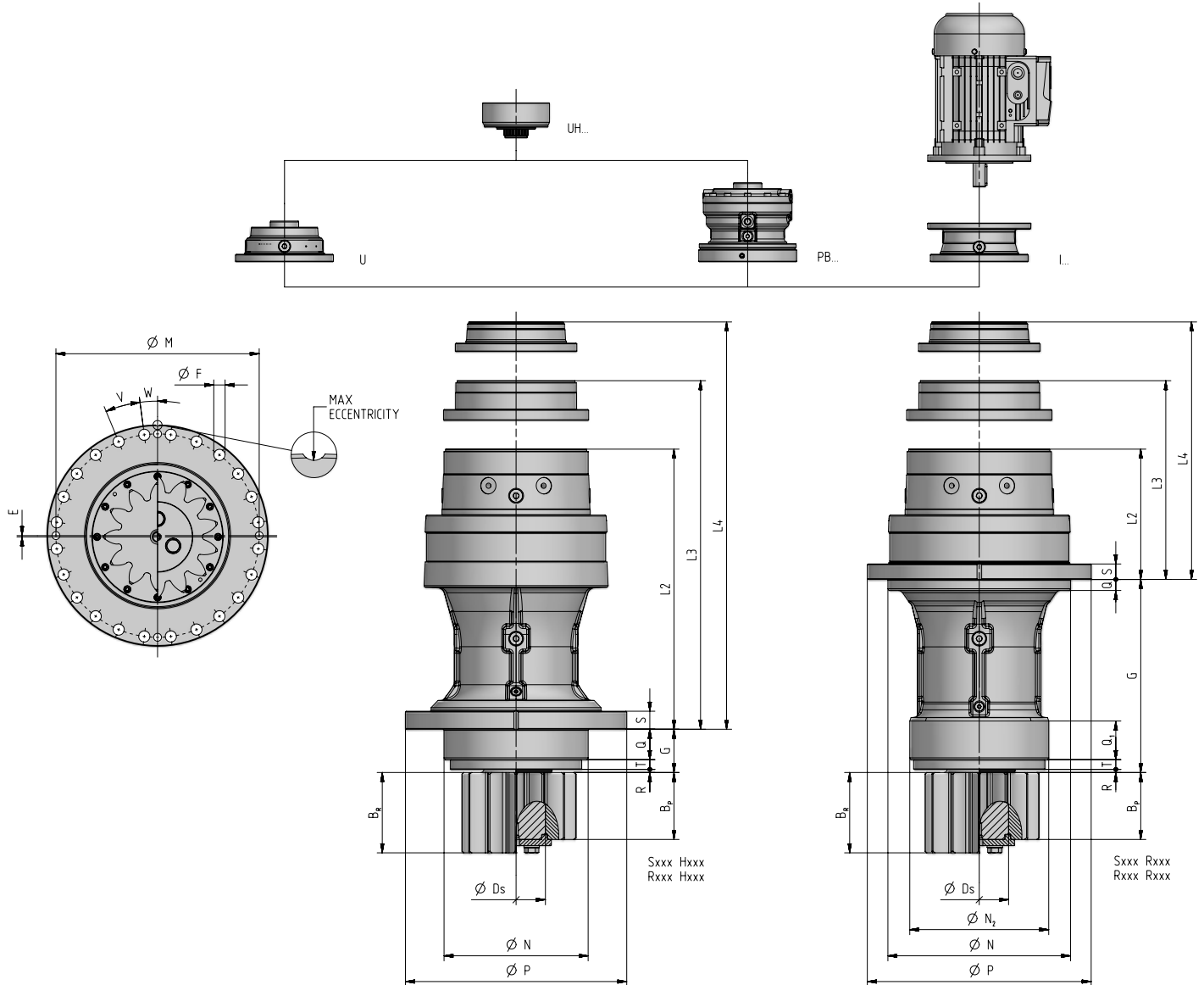

Type	X	P	N f7	N ₂ f7	G	L	Q	Q ₁	S	R	T	M	F	V	W	E	D _s DIN5480	L2	L3	L4
R30e	353	435	355	270	375	-	18	75	30	6	19	400	17,5	24x15°	7,5°	2,5	W120x3x30x38x8f	253	326	380
R32e	353	500	410	270	375	-	25	75	25	6	25	460	22	24x15°	7,5°	2	W120x3x30x38x8f	253	326	380
H30e	353	430	280	-	84	-	59	-	35	6	19	395	22	24x15°	7,5°	2,5	W120x3x30x38x8f	544	617	671

	Pinion code	m	z	x	B _R B _P	Output type	Material	Internal bore
Integral pinion	R1612b	16	12	0,5	210	R30e	case hardened and ground steel	
	R1614	16	14	0,375	145	R32e	case hardened and ground steel	
Loose pinion	R042FFb	14	16	0,5	105	*	case hardened and ground steel	N120x3x30x38x9h DIN5480
	R030FFb	14	16	0,5	110	*	case hardened and ground steel	A100x94-10h DIN5482
	R042GGb	16	17	0,5	130	*	through hardened and nitrited steel	N120x3x30x38x9h DIN5480

* For all the output types H, R and S.

Size 042A

According to FEM 1.001 L2/T5/M5 conditions

	i_n	i_{eff}	$n_1 \text{ min}^{-1}$								$M_{N2 \text{ FEM max}}$ N m	M_{2max} N m	n_{1max} min ⁻¹	n_{1peak} min ⁻¹
			2 800		1 400		900		500					
			n_2 min ⁻¹	$M_{N2 \text{ FEM}}$ N m	n_2 min ⁻¹	$M_{N2 \text{ FEM}}$ N m	n_2 min ⁻¹	$M_{N2 \text{ FEM}}$ N m	n_2 min ⁻¹	$M_{N2 \text{ FEM}}$ N m				
2EL	12,5													
	14	14,7	-	-	95,2	45 000	61,2	47 000	34,0	49 900	50 000	60 800	2 240	2 800
	16													
	18	17,5	-	-	80,2	45 800	51,6	47 900	28,6	50 000	50 000	67 000	2 240	3 150
	20	20,4	-	-	68,6	38 400	44,1	40 100	24,5	42 600	47 500	67 000	2 240	3 150
	22,4	22,1	-	-	63,2	38 300	40,7	40 100	22,6	42 600	50 000	64 900	2 240	3 550
	25	25,9	-	-	54,1	39 300	34,8	41 100	19,3	43 600	47 500	67 000	2 240	3 550
	28	28,7	-	-	48,8	39 700	31,4	41 500	17,4	44 100	47 500	66 400	2 240	3 550
	31,5	30,4	-	-	46,1	39 400	29,6	41 200	16,5	43 700	45 100	53 100	2 240	3 550
	35,5	37,3	-	-	37,5	29 900	24,1	31 300	13,4	33 200	37 900	45 100	2 240	3 550
40														
45														
3EL	50	51,7	-	-	27,1	50 000	17,4	50 000	9,66	50 000	50 000	60 800	2 500	2 800
	63	61,4	45,6	48 500	22,8	50 000	14,7	50 000	8,14	50 000	50 000	60 800	2 800	3 550
	71	72,9	38,4	49 300	19,2	50 000	12,4	50 000	6,86	50 000	50 000	67 000	2 800	3 550
	80	77,9	36,0	49 600	18,0	50 000	11,6	50 000	6,42	50 000	50 000	60 800	2 800	4 000
	90	92,4	30,3	50 000	15,2	50 000	9,74	50 000	5,41	50 000	50 000	67 000	2 800	4 000
	100	108	25,8	50 000	12,9	50 000	8,30	50 000	4,61	50 000	50 000	67 000	2 800	4 000
	112	117	23,9	42 400	11,9	45 500	7,68	47 600	4,27	50 000	50 000	64 900	2 800	4 000
	125	127	22,1	43 000	11,0	46 200	7,10	47 500	3,94	47 500	47 500	67 000	2 800	4 000
	140	138	20,4	43 100	10,2	46 300	6,54	48 400	3,63	50 000	50 000	64 900	2 800	4 000
	160	169	16,6	44 000	8,28	47 300	5,32	49 500	2,96	50 000	50 000	64 900	2 800	4 000
	180	178	15,7	44 500	7,85	47 500	5,05	47 500	2,81	47 500	47 500	66 400	2 800	4 000
	200	198	14,2	45 000	7,08	47 500	4,55	47 500	2,53	47 500	47 500	67 000	2 800	4 000
	224	219	12,8	45 500	6,39	47 500	4,11	47 500	2,28	47 500	47 500	66 400	2 800	4 000
250	232	12,1	45 100	6,03	45 100	3,88	45 100	2,16	45 100	45 100	53 100	2 800	4 000	
4EL	180	182	15,4	50 000	7,69	50 000	4,95	50 000	2,75	50 000	50 000	60 800	2 800	3 150
	200	216	13,0	50 000	6,48	50 000	4,17	50 000	2,32	50 000	50 000	60 800	3 150	4 000
	250	256	10,9	50 000	5,46	50 000	3,51	50 000	1,95	50 000	50 000	67 000	3 150	4 000
	280	274	10,2	50 000	5,11	50 000	3,29	50 000	1,83	50 000	50 000	60 800	3 150	4 000
	315	304	9,21	50 000	4,60	50 000	2,96	50 000	1,64	50 000	50 000	67 000	3 150	4 000
	355	325	8,61	50 000	4,31	50 000	2,77	50 000	1,54	50 000	50 000	67 000	3 150	4 000
	400	386	7,26	50 000	3,63	50 000	2,33	50 000	1,30	50 000	50 000	67 000	3 150	4 000
	450	453	6,18	50 000	3,09	50 000	1,99	50 000	1,10	50 000	50 000	67 000	3 150	4 000
	500	489	5,72	50 000	2,86	50 000	1,84	50 000	1,02	50 000	50 000	67 000	3 150	4 000
	560	556	5,03	50 000	2,52	50 000	1,62	50 000	0,899	50 000	50 000	67 000	3 150	4 000
	630	595	4,71	50 000	2,35	50 000	1,51	50 000	0,841	50 000	50 000	60 800	3 150	4 000
	710	706	3,97	50 000	1,98	50 000	1,28	50 000	0,709	50 000	50 000	67 000	3 150	4 000
	800	828	3,38	50 000	1,69	50 000	1,09	50 000	0,604	50 000	50 000	67 000	3 150	4 000
	900	895	3,13	50 000	1,56	50 000	1,01	50 000	0,559	50 000	50 000	64 900	3 150	4 000
	1000	1051	2,67	50 000	1,33	50 000	0,857	50 000	0,476	50 000	50 000	64 900	3 150	4 000
	1120	1160	2,41	47 500	1,21	47 500	0,776	47 500	0,431	47 500	47 500	66 400	3 150	4 000
	1250	1291	2,17	50 000	1,08	50 000	0,697	50 000	0,387	50 000	50 000	64 900	3 150	4 000
	1400	1361	2,06	47 500	1,03	47 500	0,661	47 500	0,367	47 500	47 500	66 400	3 150	4 000
1600	1509	1,86	47 500	0,928	47 500	0,596	47 500	0,331	47 500	47 500	67 000	3 150	4 000	
1800	1673	1,67	47 500	0,837	47 500	0,538	47 500	0,299	47 500	47 500	66 400	3 150	4 000	
2000														
2240														
2500														
2800														

Size 042A

H - Front fixing flange output support

R - Double pilot extended output support, with flange

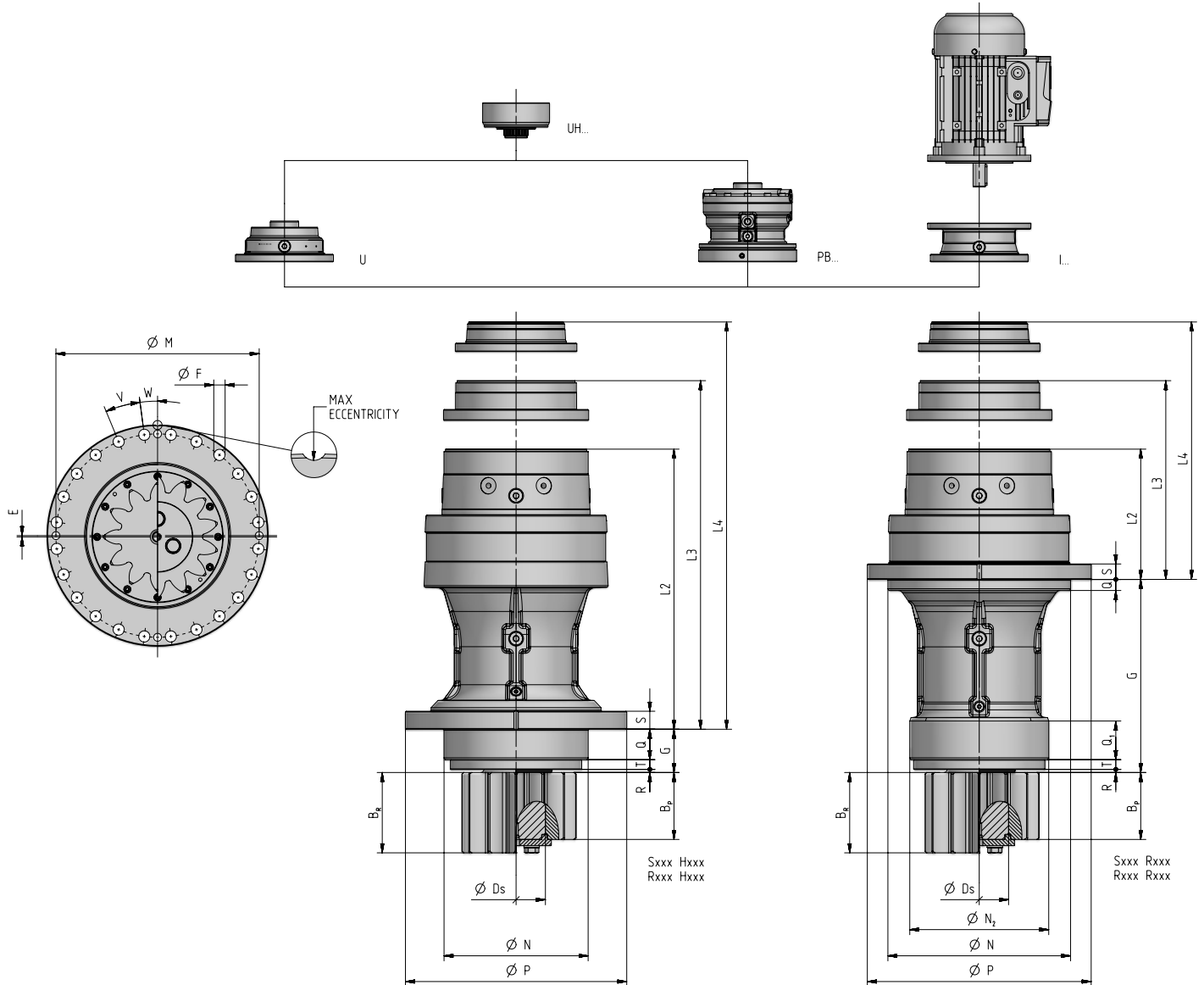

Type	X	P	N f7	N ₂ f7	G	L	Q	Q ₁	S	R	T	M	F	V	W	E	D _s DIN5480	L2	L3	L4
R30f	410	500	425	300	350	-	20	90	30	5	17	460	22	24x15°	7,5°	2,5	130x3x30x42x8f	273	355	415
R31f	410	500	425	300	350	-	20	93	30	5	17	460	22	24x15°	0°	0	130x3x30x42x8f	273	355	415
R33f	410	500	425	300	350	-	18	93	30	5	17	460	22	24x15°	7,5°	2,5	130x3x30x42x8f	273	355	415
H30f	410	435	300	-	83	-	61	-	30	5	17	395	22	24x15°	7,5°	2,5	130x3x30x42x8f	540	623	682
H31f	410	430	300	-	83	-	40	-	30	5	43	395	22	24x15°	7,5°	2,5	130x3x30x42x8f	540	623	682
H32f	410	435	315	-	113	-	60	-	30	5	17	395	22	24x15°	7,5°	-	130x3x30x42x8f	540	623	682

	Pinion code	m	z	x	B _R B _P	Output type
Integral pinion	R1812a R2011a	18 20	12 11	0,5 0,5	150 205	
Loose pinion						

Size 060A

According to FEM 1.001 L2/T5/M5 conditions

	i_N	i_{eff}	$n_1 \text{ min}^{-1}$								$M_{N2 \text{ FEM max}}$ N m	M_{2max} N m	n_{1max} min ⁻¹	n_{1peak} min ⁻¹
			2 800		1 400		900		500					
			n_2 min ⁻¹	$M_{N2 \text{ FEM}}$ N m	n_2 min ⁻¹	$M_{N2 \text{ FEM}}$ N m	n_2 min ⁻¹	$M_{N2 \text{ FEM}}$ N m	n_2 min ⁻¹	$M_{N2 \text{ FEM}}$ N m				
2EL	12,5													
	14	14,4	-	-	97,3	58 700	62,5	61 400	34,7	63 500	63 500	79 400	2 000	2 800
	16	17,1	-	-	82,0	59 700	52,7	62 400	29,3	66 200	71 000	95 000	2 000	2 800
	18	18,5	-	-	75,8	47 300	48,7	49 500	27,1	52 500	67 000	90 000	2 000	2 800
	20													
	22,4	21,7	-	-	64,6	61 200	41,6	63 900	23,1	67 800	71 000	95 000	2 000	2 800
	25	24	-	-	58,3	50 800	37,5	53 100	20,8	56 400	59 500	84 100	2 000	2 800
	28	27,8	-	-	50,4	49 300	32,4	51 600	18,0	54 700	67 000	90 000	2 000	2 800
	31,5	30,8	-	-	45,5	49 900	29,2	52 100	16,2	55 300	67 000	90 000	2 000	2 800
	35,5	32,6	-	-	42,9	50 100	27,6	52 400	15,3	55 600	67 000	86 600	2 000	2 800
40	40,1	-	-	34,9	39 800	22,4	41 700	12,5	44 200	60 100	71 300	2 000	2 800	
45														
3EL	50	50,6	-	-	27,7	62 100	17,8	63 500	9,88	63 500	63 500	79 400	2 500	2 800
	63	60,1	46,6	63 200	23,3	63 500	15,0	63 500	8,33	63 500	63 500	79 400	2 800	3 550
	71	71,3	39,3	64 300	19,6	68 900	12,6	71 000	7,02	71 000	71 000	95 000	2 800	3 550
	80	76,2	36,8	59 200	18,4	63 500	11,8	63 500	6,56	63 500	63 500	79 400	2 800	4 000
	90	90,4	31,0	65 900	15,5	70 600	9,96	71 000	5,53	71 000	71 000	95 000	2 800	4 000
	100	106	26,4	59 300	13,2	63 700	8,48	66 700	4,71	70 900	71 000	90 000	2 800	4 000
	112	115	24,4	67 400	12,2	71 000	7,85	71 000	4,36	71 000	71 000	95 000	2 800	4 000
	125	127	22,0	56 100	11,0	59 500	7,08	59 500	3,94	59 500	59 500	84 100	2 800	4 000
	140	135	20,8	68 500	10,4	71 000	6,69	71 000	3,72	71 000	71 000	95 000	2 800	4 000
	160	163	17,2	55 000	8,59	59 000	5,52	61 100	3,07	63 900	67 000	90 000	2 800	4 000
	180	183	15,3	58 300	7,64	59 500	4,91	59 500	2,73	59 500	59 500	84 100	2 800	4 000
	200	203	13,8	56 200	6,91	60 100	4,44	62 100	2,47	65 000	67 000	86 600	2 800	4 000
	224	212	13,2	56 500	6,60	60 300	4,24	62 400	2,36	65 200	67 000	90 000	2 800	4 000
250	249	11,2	57 400	5,62	61 000	3,61	63 100	2,01	66 000	67 000	86 600	2 800	4 000	
4EL	180	178	15,7	63 500	7,87	63 500	5,06	63 500	2,81	63 500	63 500	79 400	2 800	3 150
	200	211	13,3	71 000	6,63	71 000	4,26	71 000	2,37	71 000	71 000	95 000	2 800	3 150
	250	251	11,2	71 000	5,58	71 000	3,59	71 000	1,99	71 000	71 000	95 000	2 800	3 150
	280	297	9,41	71 000	4,71	71 000	3,03	71 000	1,68	71 000	71 000	95 000	3 150	4 000
	315	318	8,81	63 500	4,40	63 500	2,83	63 500	1,57	63 500	63 500	79 400	3 150	4 000
	355	344	8,14	59 300	4,07	62 600	2,62	64 700	1,45	67 000	67 000	90 000	3 150	4 000
	400	377	7,42	71 000	3,71	71 000	2,39	71 000	1,33	71 000	71 000	95 000	3 150	4 000
	450	443	6,32	71 000	3,16	71 000	2,03	71 000	1,13	71 000	71 000	95 000	3 150	4 000
	500	479	5,85	71 000	2,93	71 000	1,88	71 000	1,04	71 000	71 000	95 000	3 150	4 000
	560	562	4,98	71 000	2,49	71 000	1,60	71 000	0,890	71 000	71 000	95 000	3 150	4 000
	630	607	4,61	71 000	2,31	71 000	1,48	71 000	0,824	71 000	71 000	95 000	3 150	4 000
	710	713	3,93	71 000	1,96	71 000	1,26	71 000	0,702	71 000	71 000	95 000	3 150	4 000
	800	836	3,35	71 000	1,67	71 000	1,08	71 000	0,598	71 000	71 000	95 000	3 150	4 000
	900	876	3,20	71 000	1,60	71 000	1,03	71 000	0,571	71 000	71 000	95 000	3 150	4 000
	1000	1028	2,72	71 000	1,36	71 000	0,876	71 000	0,486	71 000	71 000	95 000	3 150	4 000
	1120	1124	2,49	64 900	1,25	67 000	0,801	67 000	0,445	67 000	67 000	90 000	3 150	4 000
	1250	1245	2,25	65 400	1,12	67 000	0,723	67 000	0,402	67 000	67 000	90 000	3 150	4 000
	1400	1462	1,92	66 200	0,958	67 000	0,616	67 000	0,342	67 000	67 000	90 000	3 150	4 000
1600	1621	1,73	66 800	0,864	67 000	0,555	67 000	0,308	67 000	67 000	90 000	3 150	4 000	
1800	1796	1,56	67 000	0,779	67 000	0,501	67 000	0,278	67 000	67 000	90 000	3 150	4 000	
2000														
2240														
2500														
2800														

Size 060A

H - Front fixing flange output support

R - Double pilot extended output support, with flange

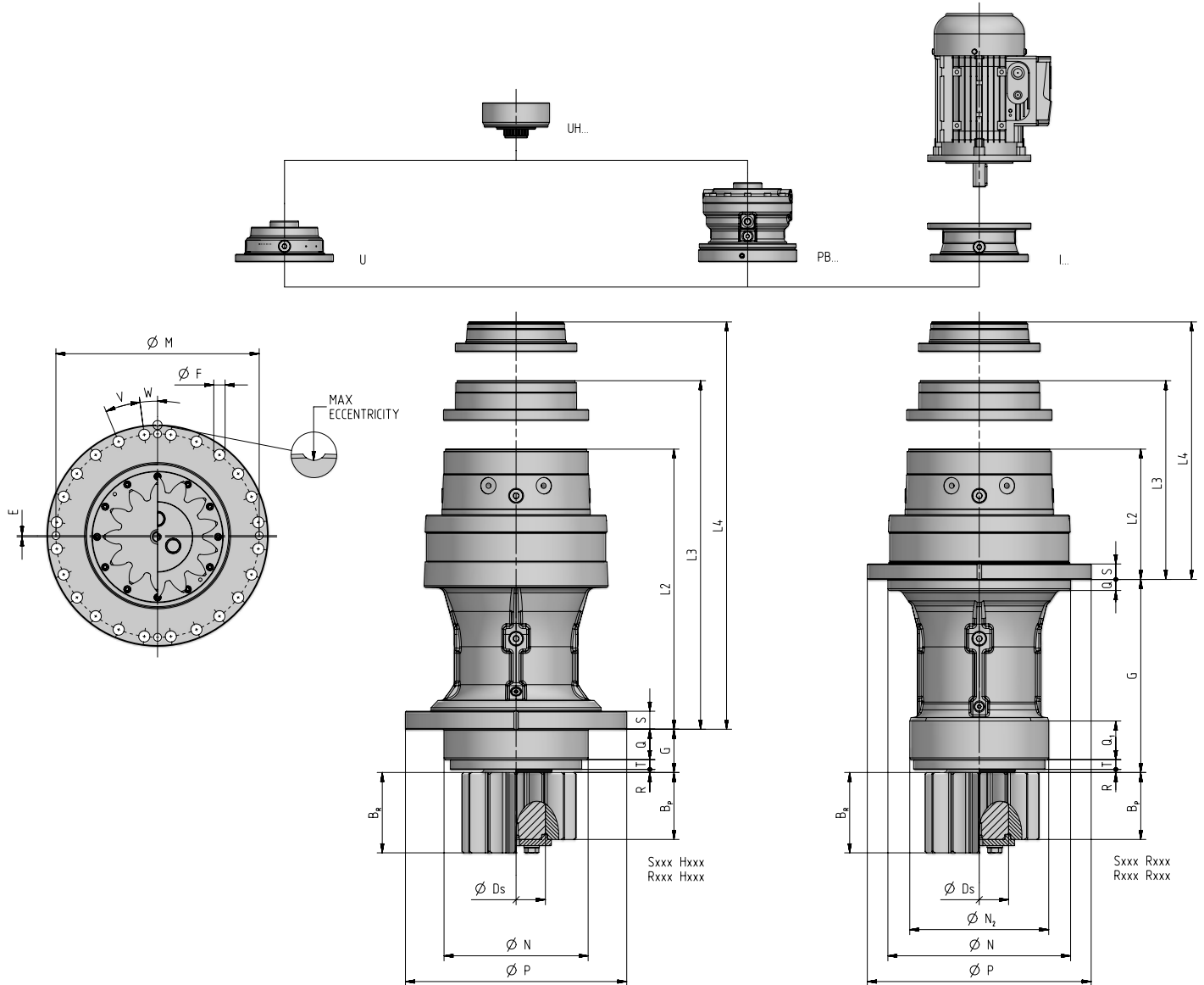

Type	X	P	N f7	N ₂ f7	G	L	Q	Q ₁	S	R	T	M	F	V	W	E	D _s DIN5480	L2	L3	L4
R30g	445	555	400	340	425	-	17,5	110	35	5	15	510	22	24x15°	7,5°	2,5	W150x5x30x28x8f	312,5	395,5	454,5
R32g	445	510	400	340	425	-	17,5	110	35	5	15	480	17,5	36x10°	5°	3	W150x5x30x28x8f	312,5	395,5	454,5
H30g	445	490	365	-	83	-	23	-	37	5	55	445	22	24x15°	7,5°	2,5	W150x5x30x28x8f	654,5	737,5	769,5

	Pinion code	m	z	x	B _R B _P	Support ordering code	Material	Internal bore DIN5480
Integral pinion								
Loose pinion	R085JEb	22	15	0,5	120	*	case hardened and ground steel	N 150x5-9H

* For all the output types H, R and S.

Size 085A

According to FEM 1.001 L2/T5/M5 conditions

	i_N	i_{eff}	$n_1 \text{ min}^{-1}$								$M_{N2 \text{ FEM max}}$ N m	$M_{2 \text{ max}}$ N m	$n_{1 \text{ max}}$ min^{-1}	$n_{1 \text{ peak}}$ min^{-1}
			2 800		1 400		900		500					
			n_2 min^{-1}	$M_{N2 \text{ FEM}}$ N m	n_2 min^{-1}	$M_{N2 \text{ FEM}}$ N m	n_2 min^{-1}	$M_{N2 \text{ FEM}}$ N m	n_2 min^{-1}	$M_{N2 \text{ FEM}}$ N m				
2EL	12,5													
	14													
	16	17,1	-	-	82,0	88 100	52,7	92 100	29,3	97 400	112 000	150 000	2 000	2 800
	18													
	20													
	22,4	21,9	-	-	63,9	87 400	41,1	91 400	22,8	97 100	112 000	150 000	2 000	2 800
	25	24,4	-	-	57,3	71 100	36,8	74 400	20,5	79 000	112 000	150 000	2 000	2 800
	28	27,8	-	-	50,4	78 300	32,4	81 900	18,0	86 800	106 000	140 000	2 000	2 800
	31,5	31,0	-	-	45,1	79 200	29,0	82 800	16,1	87 800	106 000	140 000	2 000	2 800
	35,5													
40														
45														
3EL	50													
	63	60,1	-	-	23,3	98 700	15,0	101 000	8,33	105 000	112 000	150 000	2 240	2 800
	71	71,3	-	-	19,6	99 800	12,6	102 000	7,02	106 000	112 000	150 000	2 240	3 150
	80	77,1	-	-	18,2	99 300	11,7	103 000	6,49	107 000	112 000	150 000	2 240	2 800
	90	90,4	-	-	15,5	101 000	9,96	104 000	5,53	108 000	112 000	150 000	2 240	3 550
	100	106	-	-	13,2	102 000	8,48	105 000	4,71	109 000	112 000	150 000	2 240	3 550
	112	116	-	-	12,1	103 000	7,76	106 000	4,31	109 000	112 000	150 000	2 240	3 550
	125	129	-	-	10,8	91 400	6,95	95 300	3,86	99 500	106 000	140 000	2 240	3 150
	140	136	-	-	10,3	104 000	6,61	107 000	3,67	110 000	112 000	150 000	2 240	3 550
	160	167	-	-	8,37	105 000	5,38	108 000	2,99	112 000	112 000	150 000	2 240	3 550
	180	187	-	-	7,50	87 500	4,82	91 600	2,68	97 200	112 000	150 000	2 240	3 550
	200	193	-	-	7,27	95 000	4,67	98 100	2,59	103 000	106 000	140 000	2 240	3 550
	224	212	-	-	6,60	95 600	4,24	98 900	2,36	103 000	106 000	140 000	2 240	3 550
250	237	-	-	5,91	96 400	3,80	99 700	2,11	104 000	106 000	140 000	2 240	3 550	
4EL	180													
	200	211	-	-	6,63	107 000	4,26	109 000	2,37	112 000	112 000	150 000	2 500	2 800
	250	251	11,2	103 000	5,58	108 000	3,59	111 000	1,99	112 000	112 000	150 000	2 800	3 550
	280	297	9,41	104 000	4,71	109 000	3,03	112 000	1,68	112 000	112 000	150 000	2 800	3 550
	315	318	8,81	105 000	4,40	109 000	2,83	112 000	1,57	112 000	112 000	150 000	2 800	4 000
	355	344	-	-	4,07	99 200	2,62	102 000	1,45	106 000	106 000	140 000	2 500	2 800
	400	382	7,33	106 000	3,67	110 000	2,36	112 000	1,31	112 000	112 000	150 000	2 800	3 550
	450	443	6,32	107 000	3,16	111 000	2,03	112 000	1,13	112 000	112 000	150 000	2 800	4 000
	500	479	5,85	107 000	2,93	112 000	1,88	112 000	1,04	112 000	112 000	150 000	2 800	4 000
	560	562	4,98	108 000	2,49	112 000	1,60	112 000	0,890	112 000	112 000	150 000	2 800	4 000
	630	659	4,25	109 000	2,12	112 000	1,36	112 000	0,758	112 000	112 000	150 000	2 800	4 000
	710	721	3,88	110 000	1,94	112 000	1,25	112 000	0,694	112 000	112 000	150 000	2 800	4 000
	800	846	3,31	111 000	1,65	112 000	1,06	112 000	0,591	112 000	112 000	150 000	2 800	4 000
	900	886	3,16	111 000	1,58	112 000	1,02	112 000	0,564	112 000	112 000	150 000	2 800	4 000
	1000	1040	2,69	112 000	1,35	112 000	0,865	112 000	0,481	112 000	112 000	150 000	2 800	4 000
	1120	1124	2,49	103 000	1,25	106 000	0,801	106 000	0,445	106 000	106 000	140 000	2 800	4 000
	1250	1278	2,19	112 000	1,10	112 000	0,704	112 000	0,391	112 000	112 000	150 000	2 800	4 000
	1400	1471	1,90	105 000	0,951	106 000	0,612	106 000	0,340	106 000	106 000	140 000	2 800	4 000
	1600	1621	1,73	106 000	0,864	106 000	0,555	106 000	0,308	106 000	106 000	140 000	2 800	4 000
1800	1808	1,55	106 000	0,774	106 000	0,498	106 000	0,277	106 000	106 000	140 000	2 800	4 000	
2000														
2240														
2500														
2800														

Size 085A

H - Front fixing flange output support

R - Double pilot extended output support, with flange

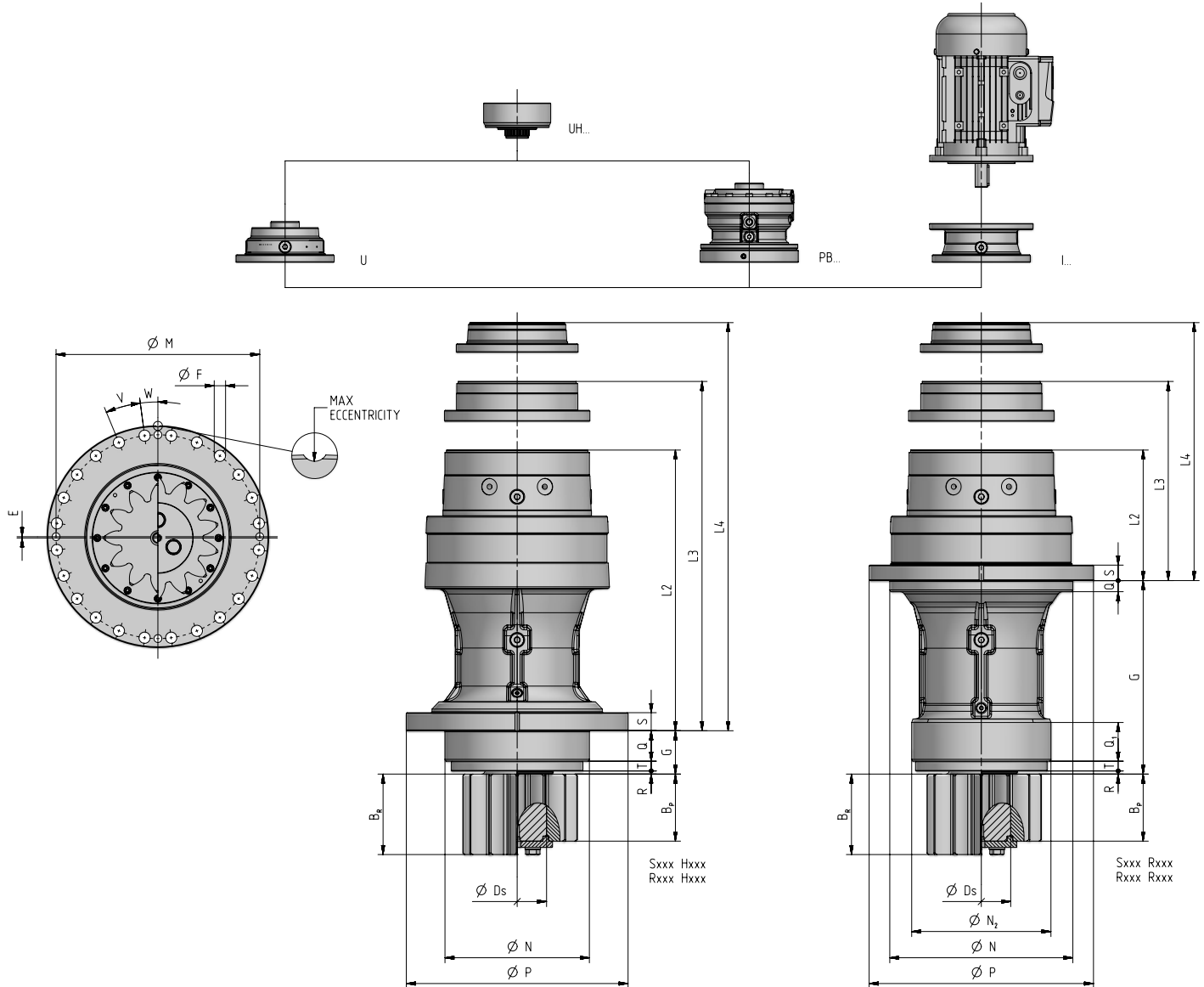

Type	X	P	N f7	N ₂ f7	G	L	Q	Q ₁	S	R	T	M	F	V	W	E	D _s DIN5480	L2	L3	L4
R30h	506	640	470	370	470	-	20	125	35	5	15	600	22	24x15°	7,5°	2,5	170x5x30x32x8f	450	503	576
R31h	506	640	470	410	470	-	20	100	35	5	20	600	22	24x15°	0°	2,5	170x5x30x32x8f	450	503	576
H30h	506	540	435	-	100	-	25	-	41	5	65	485	33	24x15°	7,5°	2,5	170x5x30x32x8f	820	873	946

	Pinion code	m	z	x	B _R B _P	Support ordering code	Material	Internal bore DIN5480
Loose pinion	R125HGb	18	17	0,5	205	*	through hardened and nitrited steel	N170x5x30x32
	R125HMb	18	23	0,5	140	*	case hardened and ground steel	N170x5x30x32-8f
	R125IEb	20	15	0,5	180	*	case hardened and ground steel	N170x5x30x32-9H

* For all the output types H, R and S.

Size 125A

According to FEM 1.001 L2/T5/M5 conditions

	\dot{n}	i_{eff}	$n_1 \text{ min}^{-1}$								$M_{N2 \text{ FEM max}}$ N m	M_{zmax} N m	n_{1max} min ⁻¹	n_{1peak} min ⁻¹
			2 800		1 400		900		500					
			n_2 min ⁻¹	$M_{N2 \text{ FEM}}$ N m	n_2 min ⁻¹	$M_{N2 \text{ FEM}}$ N m	n_2 min ⁻¹	$M_{N2 \text{ FEM}}$ N m	n_2 min ⁻¹	$M_{N2 \text{ FEM}}$ N m				
2EL	12,5													
	14													
	16													
	18	17,5	-	-	80,2	126 000	51,6	132 000	28,6	137 000	160 000	212 000	2 000	2 800
	20	20,4	-	-	68,6	128 000	44,1	133 000	24,5	138 000	160 000	212 000	2 000	2 800
	22,4	22,1	-	-	63,2	102 000	40,7	106 000	22,6	113 000	150 000	200 000	2 000	2 800
	25	25,0	-	-	55,9	106 000	35,9	111 000	20,0	118 000	160 000	212 000	2 000	2 800
	28	25,9	-	-	54,1	103 000	34,8	108 000	19,3	114 000	150 000	200 000	2 000	2 800
	31,5	31,8	-	-	44,1	105 000	28,3	110 000	15,7	117 000	150 000	200 000	2 000	2 800
	35,5													
40														
45														
3EL	50													
	63	61,4	-	-	22,8	139 000	14,7	142 000	8,14	148 000	160 000	212 000	2 240	2 800
	71	72,9	-	-	19,2	140 000	12,4	144 000	6,86	149 000	160 000	212 000	2 240	3 150
	80	85,2	-	-	16,4	141 000	10,6	145 000	5,87	150 000	160 000	212 000	2 240	3 150
	90	92,4	-	-	15,2	142 000	9,74	146 000	5,41	151 000	160 000	212 000	2 240	3 550
	100	102	-	-	13,7	143 000	8,79	147 000	4,88	152 000	160 000	212 000	2 240	3 550
	112	108	-	-	13,0	143 000	8,33	147 000	4,63	153 000	160 000	212 000	2 240	3 550
	125	120	-	-	11,7	144 000	7,52	148 000	4,18	154 000	160 000	212 000	2 240	3 550
	140	133	-	-	10,6	126 000	6,79	132 000	3,77	140 000	160 000	212 000	2 240	3 550
	160	168	-	-	8,33	124 000	5,35	129 000	2,97	134 000	150 000	200 000	2 240	3 550
	180	186	-	-	7,51	126 000	4,83	130 000	2,68	135 000	150 000	200 000	2 240	3 550
	200	198	-	-	7,08	126 000	4,55	130 000	2,53	136 000	150 000	200 000	2 240	3 550
	224													
250	243	-	-	5,77	128 000	3,71	132 000	2,06	138 000	150 000	200 000	2 240	3 550	
4EL	180													
	200	216	-	-	6,48	150 000	4,17	154 000	2,32	160 000	160 000	212 000	2 500	2 800
	250	256	10,9	145 000	5,46	151 000	3,51	155 000	1,95	160 000	160 000	212 000	2 800	3 550
	280	300	9,35	146 000	4,67	153 000	3,00	157 000	1,67	160 000	160 000	212 000	2 800	3 550
	315	325	8,61	147 000	4,31	153 000	2,77	158 000	1,54	160 000	160 000	212 000	2 800	4 000
	355	356	7,88	148 000	3,94	154 000	2,53	159 000	1,41	160 000	160 000	212 000	2 800	3 550
	400	386	7,26	149 000	3,63	155 000	2,33	160 000	1,30	160 000	160 000	212 000	2 800	4 000
	450	451	6,21	150 000	3,10	156 000	2,00	160 000	1,11	160 000	160 000	212 000	2 800	4 000
	500	500	5,60	151 000	2,80	157 000	1,80	160 000	1,00	160 000	160 000	212 000	2 800	3 550
	560	572	4,90	152 000	2,45	159 000	1,57	160 000	0,874	160 000	160 000	212 000	2 800	4 000
	630	634	4,42	153 000	2,21	160 000	1,42	160 000	0,789	160 000	160 000	212 000	2 800	4 000
	710	706	3,97	154 000	1,98	160 000	1,28	160 000	0,709	160 000	160 000	212 000	2 800	4 000
	800	825	3,39	156 000	1,70	160 000	1,09	160 000	0,606	160 000	160 000	212 000	2 800	4 000
	900	914	3,06	157 000	1,53	160 000	0,984	160 000	0,547	160 000	160 000	212 000	2 800	4 000
	1000	1046	2,68	135 000	1,34	143 000	0,860	147 000	0,478	150 000	150 000	200 000	2 800	4 000
	1120	1160	2,41	136 000	1,21	144 000	0,776	149 000	0,431	150 000	150 000	200 000	2 800	4 000
	1250	1284	2,18	137 000	1,09	145 000	0,701	150 000	0,389	150 000	150 000	200 000	2 800	4 000
	1400	1423	1,97	139 000	0,984	146 000	0,632	150 000	0,351	150 000	150 000	200 000	2 800	4 000
	1600	1507	1,86	139 000	0,929	147 000	0,597	150 000	0,332	150 000	150 000	200 000	2 800	4 000
1800	1852	1,51	141 000	0,756	149 000	0,486	150 000	0,270	150 000	150 000	200 000	2 800	4 000	
2000														
2240														
2500														
2800														

Size 125A

H - Front fixing flange output support

R - Double pilot extended output support, with flange

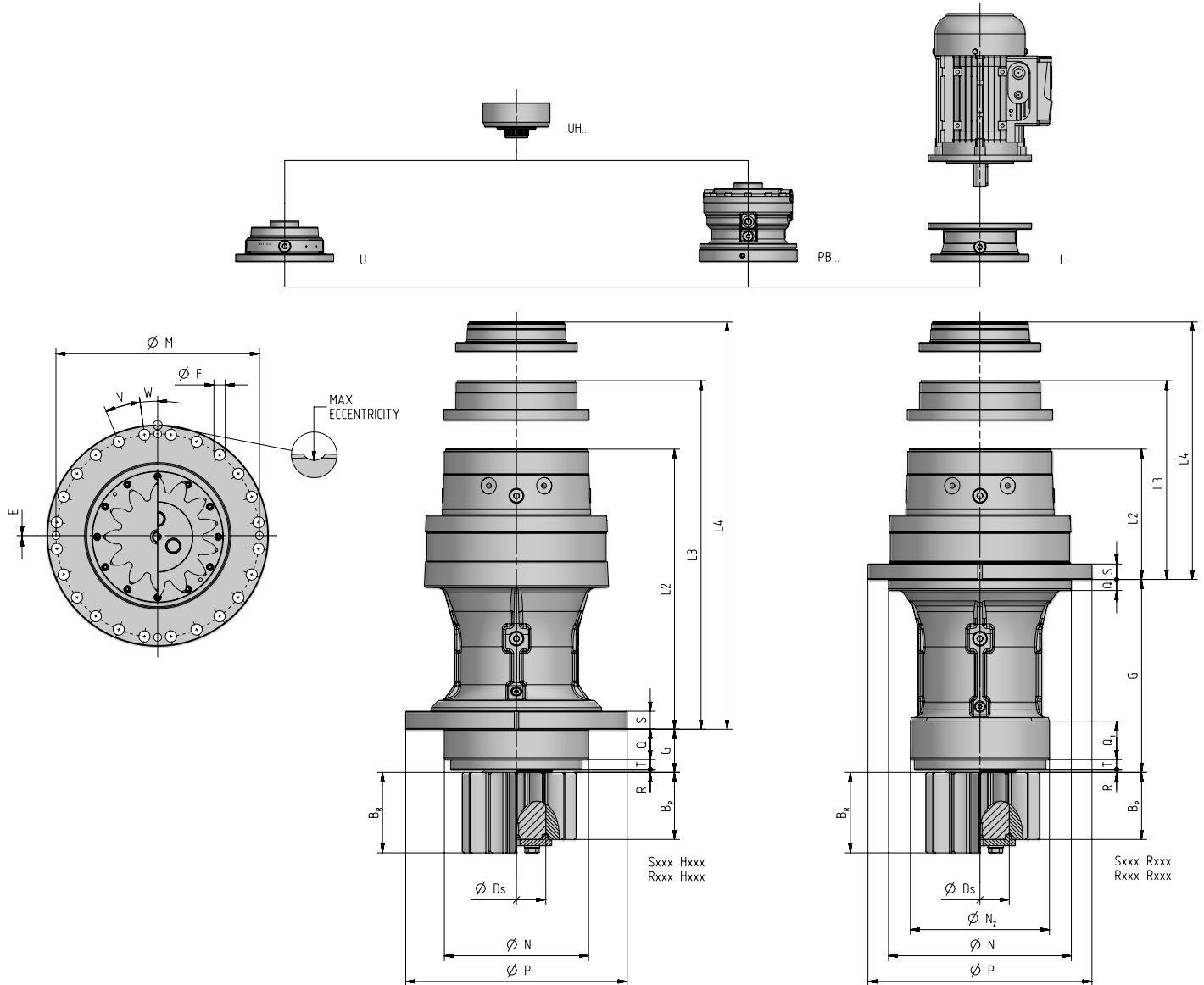

Type	X	P	N f7	N ₂ f7	G	L	Q	Q ₁	S	R	T	M	F	V	W	E	D _s DIN5480	L2	L3	L4
R30i	570	690	580	400	515	-	21	140	35	5	15	640	26	24x15°	7,5°	2,5	W200x5x30x38x8f	470,5	523,5	606,5
H30i	570	565	470	-	140	-	21	-	35	5	15	515	26	28x12,857°	6,429°	2,5	W200x5x30x38x8f	845,5	898,5	981,5

	Pinion code	m	z	x	B _R B _P	Support ordering code	Material	Internal bore
Integral pinion								
Loose pinion								

AVAILABLE ON REQUEST

Size 180A

According to FEM 1.001 L2/T5/M5 conditions

	i_n	i_{eff}	$n_1 \text{ min}^{-1}$								$M_{N2 \text{ FEM max}}$ N m	M_{2max} N m	n_{1max} min^{-1}	n_{1peak} min^{-1}	
			2 800		1 400		900		500						
			n_2 min^{-1}	$M_{N2 \text{ FEM}}$ N m	n_2 min^{-1}	$M_{N2 \text{ FEM}}$ N m	n_2 min^{-1}	$M_{N2 \text{ FEM}}$ N m	n_2 min^{-1}	$M_{N2 \text{ FEM}}$ N m					
2EL	12,5														
	14														
	16	17,1	-	-	81,8	159 000	52,6	182 000	29,2	198 000	224 000	300 000	1 800	2 500	
	18														
	20	20,0	-	-	70,0	150 000	45,0	157 000	25,0	166 000	212 000	280 000	1 800	2 500	
	22,4	22,0	-	-	63,8	169 000	41,0	177 000	22,8	188 000	224 000	300 000	1 800	2 500	
	25	24,5	-	-	57,2	138 000	36,7	144 000	20,4	153 000	224 000	300 000	1 800	2 500	
	28	28,6	-	-	48,9	155 000	31,4	162 000	17,5	172 000	212 000	280 000	1 800	2 500	
	31,5														
	35,5														
40															
45															
3EL	50														
	63	60,2	-	-	23,3	202 000	15,0	208 000	8,31	215 000	224 000	300 000	2 000	2 800	
	71	71,4	-	-	19,6	204 000	12,6	210 000	7,00	218 000	224 000	300 000	2 000	2 800	
	80	77,2	-	-	18,1	192 000	11,7	201 000	6,48	213 000	224 000	300 000	2 000	2 800	
	90	90,6	-	-	15,5	207 000	9,94	213 000	5,52	221 000	224 000	300 000	2 000	2 800	
	100	100	-	-	13,9	206 000	8,97	214 000	4,98	222 000	224 000	300 000	2 000	2 800	
	112	116	-	-	12,0	200 000	7,74	209 000	4,30	222 000	224 000	300 000	2 000	2 800	
	125	129	-	-	10,9	202 000	6,99	211 000	3,88	224 000	224 000	300 000	2 000	2 800	
	140	136	-	-	10,3	181 000	6,62	188 000	3,68	197 000	212 000	280 000	2 000	2 800	
	160	168	-	-	8,33	185 000	5,36	191 000	2,98	200 000	212 000	280 000	2 000	2 800	
	180	178	-	-	7,87	186 000	5,06	192 000	2,81	200 000	212 000	280 000	2 000	2 800	
	200														
	224	219	-	-	6,40	189 000	4,12	195 000	2,29	203 000	212 000	280 000	2 000	2 800	
250															
4EL	180														
	200	212	-	-	6,62	218 000	4,25	224 000	2,36	224 000	224 000	300 000	2 500	2 800	
	250	251	11,1	212 000	5,57	221 000	3,58	224 000	1,99	224 000	224 000	300 000	2 800	3 550	
	280	298	9,39	214 000	4,70	223 000	3,02	224 000	1,68	224 000	224 000	300 000	2 800	3 550	
	315	319	8,79	215 000	4,39	224 000	2,83	224 000	1,57	224 000	224 000	300 000	2 800	4 000	
	355	353	-	-	3,97	224 000	2,55	224 000	1,42	224 000	224 000	300 000	2 500	2 800	
	400	378	7,41	217 000	3,70	224 000	2,38	224 000	1,32	224 000	224 000	300 000	2 800	4 000	
	450	444	6,31	219 000	3,16	224 000	2,03	224 000	1,13	224 000	224 000	300 000	2 800	4 000	
	500	479	5,84	220 000	2,92	224 000	1,88	224 000	1,04	224 000	224 000	300 000	2 800	4 000	
	560	563	4,97	222 000	2,49	224 000	1,60	224 000	0,888	224 000	224 000	300 000	2 800	4 000	
	630	624	4,49	224 000	2,24	224 000	1,44	224 000	0,802	224 000	224 000	300 000	2 800	4 000	
	710	722	3,88	224 000	1,94	224 000	1,25	224 000	0,692	224 000	224 000	300 000	2 800	4 000	
	800	800	3,50	224 000	1,75	224 000	1,12	224 000	0,625	224 000	224 000	300 000	2 800	4 000	
	900	888	3,15	224 000	1,58	224 000	1,01	224 000	0,563	224 000	224 000	300 000	2 800	4 000	
	1000	984	2,85	224 000	1,42	224 000	0,915	224 000	0,508	224 000	224 000	300 000	2 800	4 000	
	1120	1150	2,44	203 000	1,22	212 000	0,783	212 000	0,435	212 000	212 000	280 000	2 800	4 000	
	1250	1283	2,18	204 000	1,09	212 000	0,702	212 000	0,390	212 000	212 000	280 000	2 800	4 000	
	1400														
1600	1670	1,68	208 000	0,838	212 000	0,539	212 000	0,299	212 000	212 000	280 000	2 800	4 000		
1800															
2000															
2240															
2500															
2800															

Size 180A

H - Front fixing flange output support

R - Double pilot extended output support, with flange

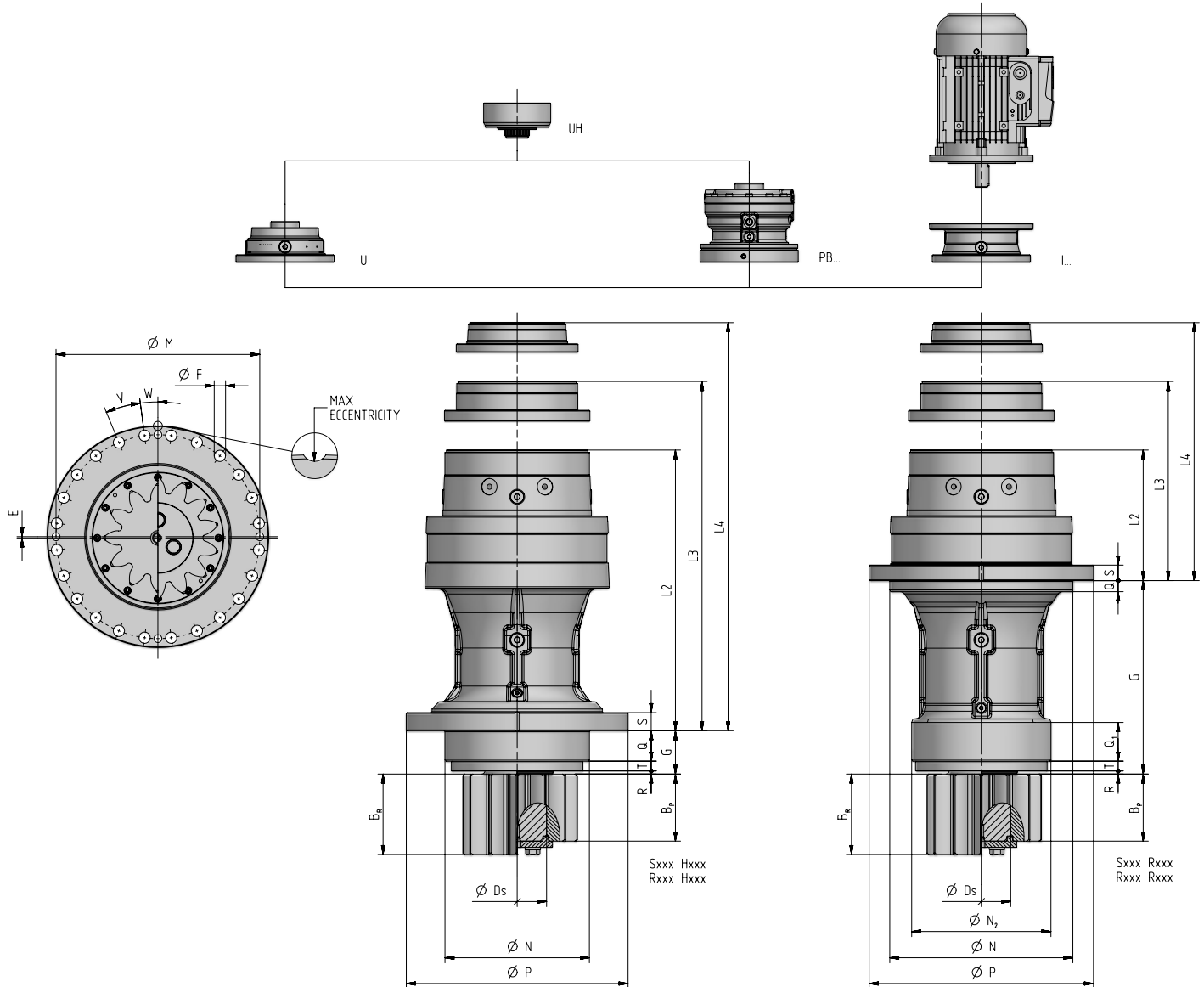

Type	X	P	N f7	N ₂ f7	G	L	Q	Q ₁	S	R	T	M	F	V	W	E	D _s DIN5480	L2	L3	L4
R30j	630	755	630	460	610	-	23	150	40	6	29	700	26	28x12,857°	6,429°	4	W220x5x30x42x8f	556	609	692
H30j	630	630	520	-	165	-	24	-	40	6	135	575	26	32x11,25°	5,625°	4	W220x5x30x42x8f	1001	1054	1137

	Pinion code	m	z	x	B _R B _p	Support ordering code	Material	Internal bore DIN5480
Integral pinion								
Loose pinion	R250IjB	20	20	0,5	205	*	case hardened and ground steel	N220x5x9H
	R250KKb	24	21	0,5	170	*	case hardened and ground steel	N220x5x9H
	R250NFb	30	16	0,5	180	*	case hardened and ground steel	N220x5x9H

* For all the output types H, R and S.

Size 250A

According to FEM 1.001 L2/T5/M5 conditions

	i_N	i_{eff}	$n_1 \text{ min}^{-1}$								$M_{N2 \text{ FEM max}}$ N m	M_{2max} N m	n_{1max} min ⁻¹	n_{1peak} min ⁻¹	
			2 800		1 400		900		500						
			n_2 min ⁻¹	$M_{N2 \text{ FEM}}$ N m	n_2 min ⁻¹	$M_{N2 \text{ FEM}}$ N m	n_2 min ⁻¹	$M_{N2 \text{ FEM}}$ N m	n_2 min ⁻¹	$M_{N2 \text{ FEM}}$ N m					
2EL	12,5														
	14														
	16														
	18	17,5	-	-	80,2	221 000	51,6	253 000	28,6	281 000	315 000	425 000	1 400	2 500	
	20	20,4	-	-	68,6	215 000	44,1	225 000	24,5	238 000	300 000	400 000	1 400	2 500	
	22,4	22,1	-	-	63,2	238 000	40,7	272 000	22,6	285 000	315 000	425 000	1 400	2 500	
	25	24,5	-	-	57,1	210 000	36,7	220 000	20,4	233 000	315 000	425 000	1 400	2 500	
	28	28,7	-	-	48,8	223 000	31,4	233 000	17,4	247 000	300 000	400 000	1 400	2 500	
	31,5														
	35,5														
40															
45															
3EL	50														
	63														
	71	71,4	-	-	19,6	288 000	12,6	296 000	7,00	306 000	315 000	425 000	2 000	2 800	
	80	83,5	-	-	16,8	247 000	10,8	258 000	5,99	271 000	300 000	400 000	2 000	2 800	
	90	91,6	-	-	15,3	292 000	9,82	300 000	5,46	311 000	315 000	425 000	2 000	2 800	
	100	102	-	-	13,7	288 000	8,80	302 000	4,89	313 000	315 000	425 000	2 000	2 800	
	112	116	-	-	12,0	296 000	7,74	304 000	4,30	315 000	315 000	425 000	2 000	2 800	
	125	130	-	-	10,8	298 000	6,94	307 000	3,86	315 000	315 000	425 000	2 000	2 800	
	140	144	-	-	9,74	251 000	6,26	263 000	3,48	279 000	315 000	425 000	2 000	2 800	
	160	168	-	-	8,33	265 000	5,36	274 000	2,98	286 000	300 000	400 000	2 000	2 800	
	180														
	200														
	4EL	180													
200															
250		251	-	-	5,57	311 000	3,58	315 000	1,99	315 000	315 000	425 000	2 240	2 800	
280		298	-	-	4,70	314 000	3,02	315 000	1,68	315 000	315 000	425 000	2 240	3 150	
315		322	-	-	4,34	315 000	2,79	315 000	1,55	315 000	315 000	425 000	2 240	2 800	
355		360	-	-	3,89	315 000	2,50	315 000	1,39	315 000	315 000	425 000	2 240	2 800	
400		382	-	-	3,66	315 000	2,35	315 000	1,31	315 000	315 000	425 000	2 240	3 150	
450		444	-	-	3,16	315 000	2,03	315 000	1,13	315 000	315 000	425 000	2 240	3 550	
500		485	-	-	2,89	315 000	1,86	315 000	1,03	315 000	315 000	425 000	2 240	3 550	
560		563	-	-	2,49	315 000	1,60	315 000	0,888	315 000	315 000	425 000	2 240	3 550	
630		635	-	-	2,20	315 000	1,42	315 000	0,787	315 000	315 000	425 000	2 240	3 550	
710		722	-	-	1,94	315 000	1,25	315 000	0,692	315 000	315 000	425 000	2 240	3 550	
800		806	-	-	1,74	315 000	1,12	315 000	0,620	315 000	315 000	425 000	2 240	3 550	
900		888	-	-	1,58	315 000	1,01	315 000	0,563	315 000	315 000	425 000	2 240	3 550	
1000		990	-	-	1,41	315 000	0,909	315 000	0,505	315 000	315 000	425 000	2 240	3 550	
1120		1150	-	-	1,22	300 000	0,783	300 000	0,435	300 000	300 000	400 000	2 240	3 550	
1250		1283	-	-	1,09	300 000	0,702	300 000	0,390	300 000	300 000	400 000	2 240	3 550	
1400															
1600															
1800															
2000															
2240															
2500															
2800															

Size 250A

H - Front fixing flange output support

R - Double pilot extended output support, with flange

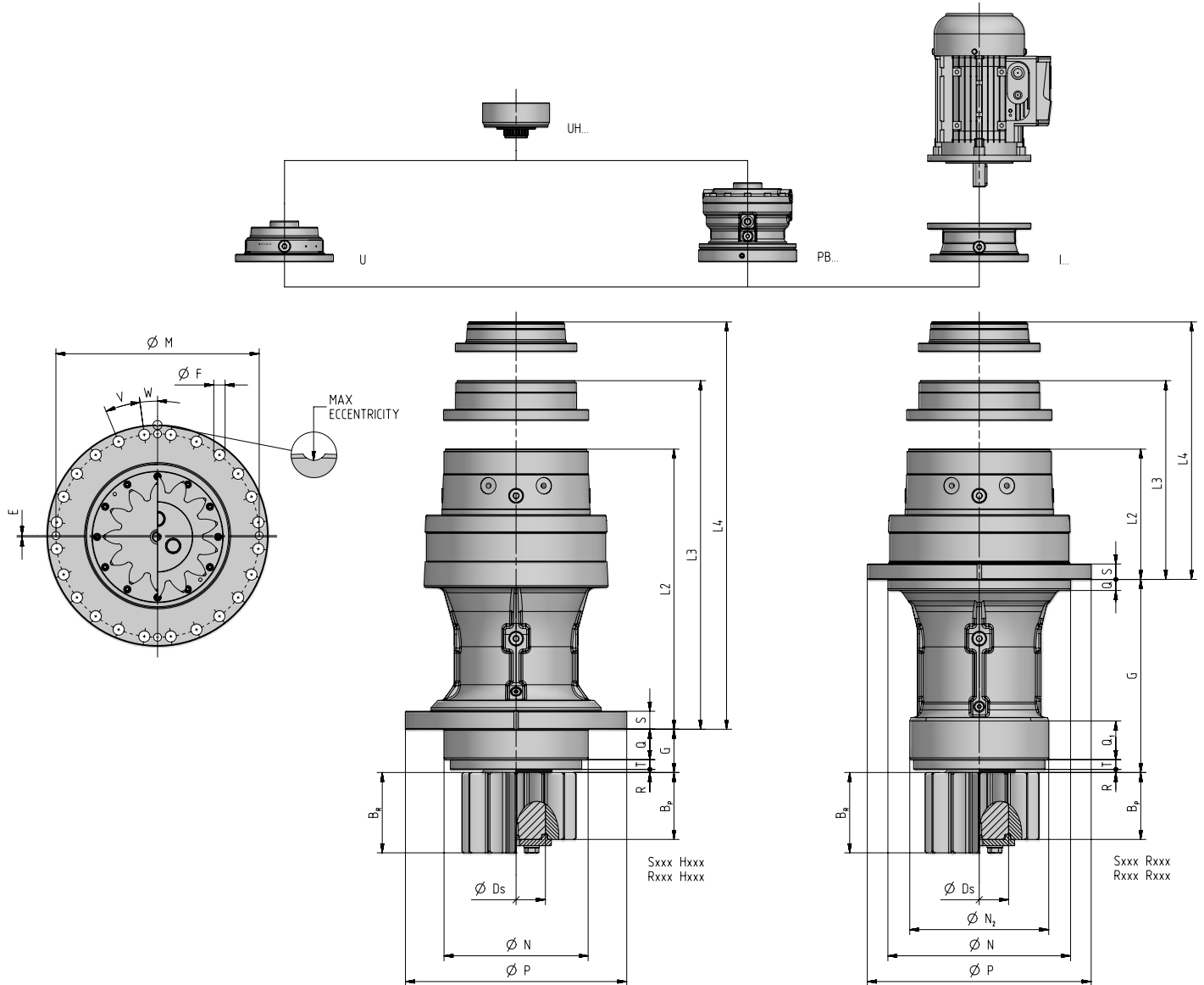

Type	X	P	N f7	N ₂ f7	G	L	Q	Q ₁	S	R	T	M	F	V	W	E	D _s DIN5480	L2	L3	L4
R30k	715	865	740	490	700	-	17	166	45	8	32	800	33	28x12,857°	6,429°	5	W240x5x30x46x8f	622	793	846
R31k	715	865	740	490	875	-	20	170	45	30	40	800	33	28x12,857°	6,429°	5	W240x5x30x46x8f	622	793	846
H30k	715	715	585	-	180	-	25	-	45	4	147	650	33	28x12,857°	6,429°	5	W240x5x30x46x8f	1142	1313	1366

	Pinion code	m	z	x	B _R B _P	Support ordering code	Material	Internal bore DIN5480
Loose pinion	R355KMb	24	23	0,5	205	*	case hardened and ground steel	N220x5x9H

AVAILABLE ON REQUEST

Output side details

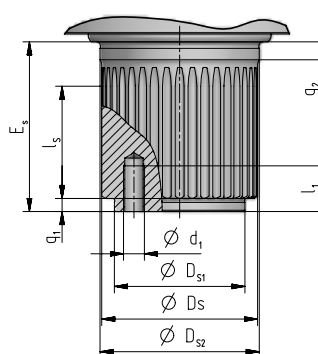
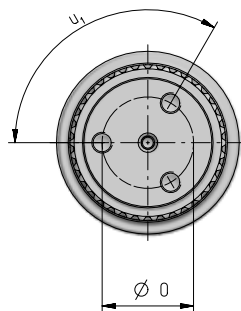

Size	Ordering code	D_s		E_s	D_{s1}	D_{s2}	d_1	l_1	O	u_1	l_s	q_1	q_2	Stop washer
007A	S070M1 ...	B70x64-e9	DIN5482	90	62 f7	72 f7	M10	21	45	3x120°	50	10	10	SW070
015A	S090M1 ...	B90x84-e9		90	80 f7	95 f7	M14	29	55	3x120°	50	10	10	SW090
021A	S100M1 ...	B100x94-e9		110	85 f7	105 f7	M14	30	65	3x120°	66	12	10,5	SW100
030A	S120M1 ...	120x3x30x38-8f	DIN5480	130	100 f7	122 f7	M16	35	70	3x120°	86	10	13,5	SW120
042A	S130M1 ...	130x3x30x42-8f		130	110 f7	132 f7	M16	33	80	3x120°	88	10	13,5	SW130
060A	S150M1 ...	150x5x30x28-8f		150	125 f7	151 f7	M16	33	95	3x120°	107	12	14	SW150
085A	S170M1 ...	170x5x30x32-8f		170	150 f7	172 f7	M16	35	115	4x90°	115	17	22	SW170
125A	S200M2 ...	200x5x30x38-8f		200	100 f7	200 f6	M20	42	150	10x36°	135	33	25	SW201
180A	S220M2 ...	220x5x30x42-8f		240	110 f7	220 f6	M20	40	170	10x36°	145	40	45	SW221
250A	S240M2 ...	240x5x30x46-8f		260	125 f7	240 f6	M24	48	185	10x36°	165	42	43	SW241

Accessories mounting

Carefully clean the coupling surfaces, apply locking adhesives (recommended only with torque arm or foot bracket) and assemble the accessory to the gear reducer. Tighten the screws by a dynamometric wrench at values shown in the following tables.

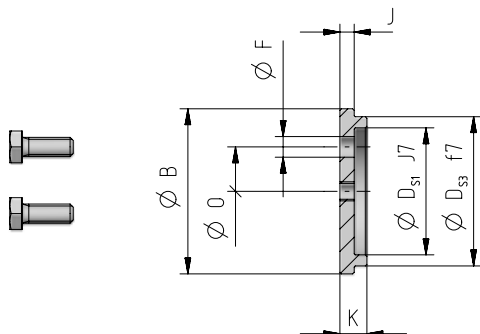

Stop washer

Code	Screw			Washer	Tightening torque [Nm]	ØB [mm]	ØO [mm]	ØF [mm]	K [mm]	J [mm]	ØD _{s1} j7 [mm]	ØD _{s3} f7 [mm]
	d x l	class	ISO									
SW070	M10x25	8.8	4017	-	50	81	45	10,5 (n.3x120°)	15,5	7,5	62	72
SW090	M14x35	8.8	4017	-	135	106	55	14,5 (n.3x120°)	18,5	10,5	80	95
SW100	M14x40	10.9	4017	6916	190	118	65	14,5 (n.3x120°)	21	10,5	85	105
SW120	M16x40	10.9	4017	6916	300	137	70	16,5 (n.3x120°)	21	12	100	122
SW130	M16x40	10.9	4017	6916	300	148	80	16,5 (n.3x120°)	21	12	110	132
SW150	M16x40	10.9	4017	6916	300	170	95	16,5 (n.3x120°)	23	12	125	151
SW170	M16x50	10.9	4017	6916	300	200	115	16,5 (n.4x90°)	34	18	150	175

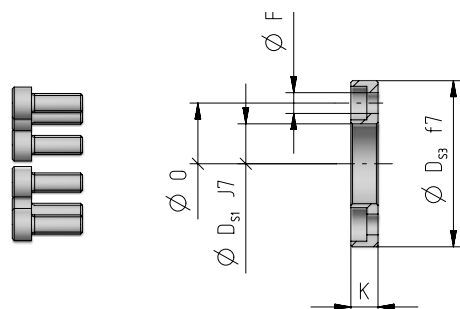

Code	screw			washer	tightening torque [Nm]	ØO [mm]	ØF [mm]	K [mm]	ØD _{s1} j7 [mm]	ØD _{s3} f7 [mm]
	d x l	class	ISO							
SW201	M20x60	10.9	4017	6916	560	150	21 (n.10x36°)	33	100	210
SW221	M20x65	10.9	4017	6916	560	170	21 (n.10x36°)	40	110	230
SW241	M24x70	10.9	4017	6916	1000	185	25 (n.10x36°)	42	125	260

Pinion gears

Design features

Standard configuration: pinion fitted on output shaft with spline DIN 5482 or DIN 5480

- Addendum modification coefficient $x = 0,5$
- Gear quality DIN 9
- Ground finish (on demand)
- Tip relief (on demand)
- Full helix modification (on demand)
- Material: tempered high alloy steel (case hardened on demand)

Only for integral pinion (on demand)

- Addendum modification coefficient $x = 0,5$
- Gear quality DIN 6
- Ground finish
- Tip relief
- Full helix modification
- Material: case hardened high alloy steel

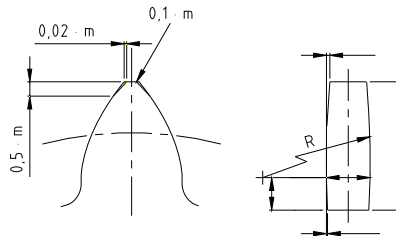

If not supplied by Rossi, the recommended minimum S value is $S_{\min} \text{ (mm)} \geq 2,2 \cdot m$ where m is the pinion module

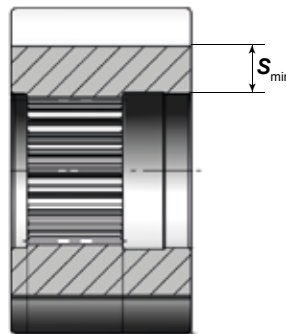

Meshing with the Slew Gear

When the pinion is supplied by Rossi, all the relevant information related to the gear geometry are given in order to allow the verification of correct pinion/gear meshing.

In particular we recommend to check the value of backlash with the corresponding slewing bearing or rack to achieve a clearance of $(0,03 - 0,04) \cdot m$ between gear teeth as shown in the following picture, taking advantage when available of the eccentric design of the gearbox output support.

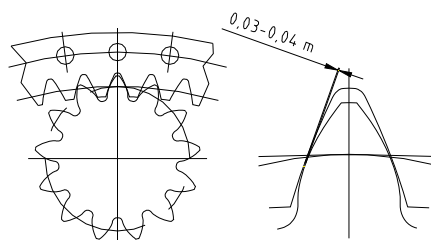

Front fixing flange output support

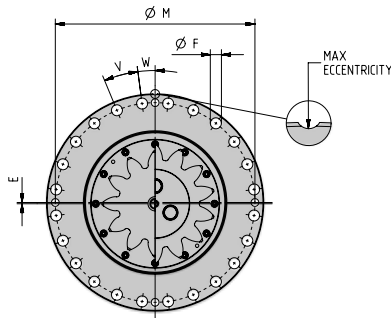

Standard configuration: pinion fitted on output shaft with spline DIN 5482 or DIN 5480.

One piece pinion-shaft on demand.

Pinion characteristics (m, z, b, x and profile modifications) to be defined according to customer's requirements.

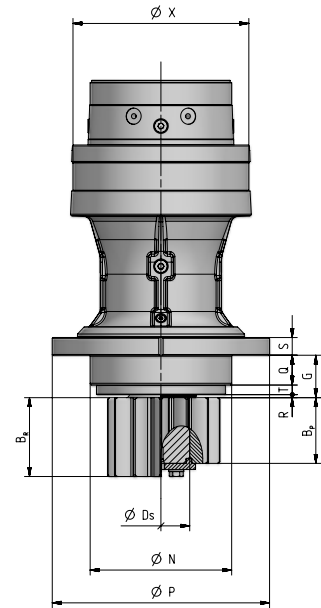

Size	Ordering code	X	P	N f7	G	Q	S	R	T	M	F	V	W	E	D _s	
007A	S070M1 H30b	234	272	175	41	15	25	4	22	245	18	10x36°	0°	1,5	B70x64	DIN5482
015A	H20c	282	280	200 g7	140	14,5	20	17	8,5	250	17	12x30°	0°	1	B90x84	
015A	S090M1 H30c	282	280	200	40	14,5	20	2,5	23	250	17	12x30°	0°	1	B90x84	
015A	* S090M1 R10c	280	280	200	45	19	20	16	25	250	17	12x30°	0°	1	B90x84	
021A	S100M1 H30d	330	400	310	80	18	30	5	57	360	22	12x30°	15°	2,5	B100x94	
021A	H33d	330	325	255 h7	78	20	35	5	53	295	16,5	24x15°	0°	1,5		
030A	S120M1 H30e	353	430	280	84	59	35	6	19	395	22	24x15°	7,5°	2,5	120x3x30x38	DIN5480
042A	S130M1 H30f	410	435	300	83	61	30	5	17	395	22	24x15°	7,5°	2,5	130x3x30x42	
042A	* S130M1 H31f	410	430	300	83	40	30	5	43	395	22	24x15°	7,5°	2,5	130x3x30x42	
060A	S150M1 H30g	445	490	365	83	23	37	5	55	445	22	24x15°	7,5°	2,5	150x5x30x28	
085A	S170M1 H30h	506	540	435	100	25	41	5	65	485	33	24x15°	7,5°	2,5	170x5x30x32	
125A	S200M2 H30i	570	565	470	140	21	35	5	15	515	26	28x12,857°	6,429°	2,5	200x5x30x38	
180A	S220M2 H30j	630	630	520	165	24	40	6	135	575	26	32x11,25°	5,625°	4	220x5x30x42	
250A	S240M2 H30k	715	715	585	180	25	45	4	147	650	33	28x12,857°	6,429°	5	240x5x30x46	

Different designs available on request.

Double pilot extended output support, with flange

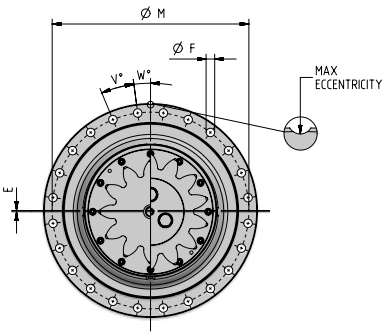

Standard configuration: pinion fitted on output shaft with spline DIN 5482 or DIN 5480.
 One piece pinion-shaft on demand.
 Pinion characteristics (m, z, b, x and profile modifications) to be defined according to customer's requirements.

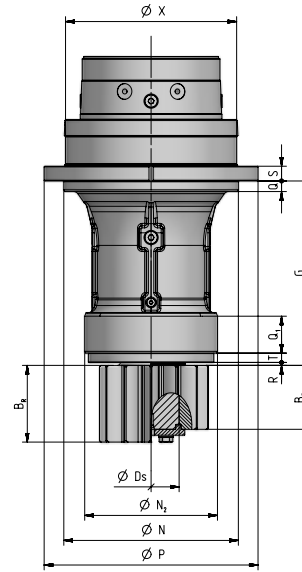

Size	Ordering code	X	P	N f7	N ₂ f7	G	Q	Q ₁	S	R	T	M	F	V	W	E	D _s
007A	S070M1 R30b	234	290	195	180	175	15	45	25	4	11	265	13	12x30°	0°	1,5	B70x64
015A	S090M1 R30c	282	360	250	200	230	13	65	25	5	12	325	17,5	10x36°	0°	2,5	B90x84
015A	R31c	282	360	250	200	230	14	65	25	5	12	325	18	12x30°	0°	2,5	
015A	R32c	282	350	290	184	292	14	50	25	11	27	325	14,5	12x30°	15°	0	
015A	R34c	282	360	250	200	230	14	65	25	5	12	325	18	12x30°	0°	1,5	
015A	R37c	282	350	290	184	292	14	50	25	11	27	325	14,5	12x30°	15°	2	
021A	S100M1 R30d	330	420	280	250	300	18	70	30	5	13	380	17,5	24x15°	7,5°	2,5	B100x94
030A	S120M1 R30e	353	435	355	270	375	18	75	30	6	19	400	17,5	24x15°	7,5°	2,5	120x3x30x38
030A	S120M1 R32e	353	500	410	270	375	25	75	25	6	25	460	22	24x15°	7,5°	2	120x3x30x38
042A	S130M1 R30f	410	500	425	300	350	20	90	30	5	17	460	22	24x15°	7,5°	2,5	130x3x30x42
042A	S130M1 R31f	410	500	425	300	350	20	93	30	5	17	460	22	24x15°	0°	0	130x3x30x42
042A	R33f	410	500	425	300	350	18	93	30	5	17	460	22	24x15°	7,5°	2,5	
060A	S150M1 R30g	445	555	400	340	425	17,5	110	35	5	15	510	22	24x15°	7,5°	2,5	150x5x30x28
060A	R32g	445	510	400	340	425	17,5	110	35	5	15	480	17,5	36x10°	5°	3	
085A	S170M1 R30h	506	640	470	370	470	20	125	35	5	15	600	22	24x15°	7,5°	2,5	170x5x30x32
085A	S170M1 R31h	506	640	470	410	470	20	100	35	5	20	600	22	24x15°	0°	2,5	170x5x30x32
125A	S200M2 R30i	570	690	580	400	515	21	140	35	5	15	640	26	24x15°	7,5°	2,5	200x5x30x38
180A	S220M2 R30j	630	755	630	460	610	23	150	40	6	29	700	26	28x12,857°	6,429°	4	220x5x30x42
250A	S240M2 R30k	715	865	740	490	700	17	166	45	8	32	800	33	28x12,857°	6,429°	5	240x5x30x46
250A	S240M2 R31k	715	865	740	490	875	20	170	45	30	40	800	33	28x12,857°	6,429°	5	240x5x30x46

DIN5482

DIN5480

Different designs available on request.

Double pilot extended output support, without flange

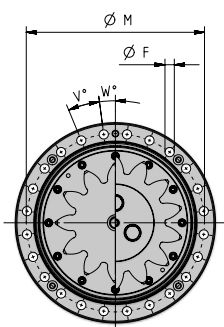

Standard configuration: pinion fitted on output shaft with spline DIN 5482 or DIN 5480.
 One piece pinion-shaft on demand.
 Pinion characteristics (m, z, b, x and profile modifications) to be defined according to customer's requirements.

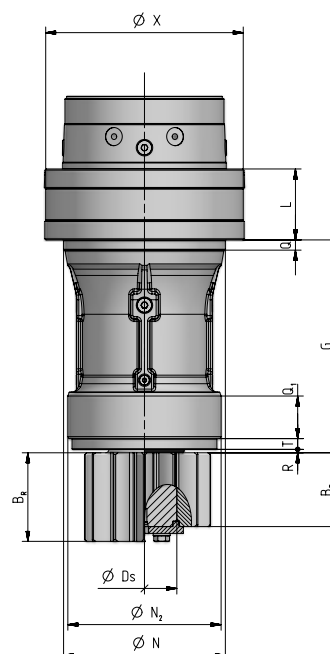

Size	Ordering code	X	N f7	N ₂ f7	G	L	Q	Q ₁	R	T	M	F	V	W	E	D _s
007A	S070M1 S30b	234	195	180	175	78	15	45	4	11	213	10,5	16x22,5°	11,25°	0	B70x64
007A	S31b	234	200	195	142	78	8	24	3	11	225	11	16x22,5°	0°	0,5	B70x64
015A	S090M1 S30c	282	235	200	235	100	18	65	5	12	255	12,5	16x22,5°	11,25°	0	B90x84
021A	S100M1 S10d	330	275	218	300	112	20	67	7	23	300	17,5	24x15°	7,5°	0,75	B100x94
021A	S100M1 S11d	330	275	250	235	103	15	59	5	26	300	17,5	24x15°	7,5°	0,75	B100x94
021A	S100M1 S30d	330	270	250	300	112	18	70	5	13	300	14,5	16x22,5°	11,25°	0	B100x94
030A	S120M1 S30e	353	285	270	375	125	16,5	75	6	19	314	16,5	24x15°	7,5°	0	120x3x30x38
042A	S130M1 S30f	410	340	300	350	145	20	90	5	17	370	16,5	28x12,857°	6,429°	0	130x3x30x42
060A	S150M1 S30g	445	365	340	425	172	18	110	5	15	400	21	24x15°	7,5°	0	150x5x30x28
085A	S170M1 S30h	506	425	370	470	185	20	125	5	15	460	22	28x12,857°	6,429°	0	170x5x30x32
125A	S200M2 S30i	570	470	400	515	175	25	140	5	15	515	25	28x12,857°	6,429°	0	200x5x30x38
180A	S220M2 S30j	630	530	460	610	195	23	150	6	29	575	25	32x11,25°	5,625°	0	220x5x30x42
250A	S240M2 S30k	715	595	490	700	223	25	168	8	32	650	32	28x12,857°	6,429°	0	240x5x30x46

DIN5482

DIN5480

Different designs available on request.

Multi-disc parking brakes

Features

The parking brakes are spring applied and hydraulic released multi-disc brakes, to be used in combination with planetary gear reducers of EP series.

They are not service brakes and they cannot be used in dynamic conditions.

They are used to hold the load from application or to stop the machine in case of emergency.

The values of static braking torque M_{Bstat} given in the following table should be considered as nominal values and are valid for a brand new brake with correct lubrication. Values of M_{Bstat} are given with a tolerance of $\pm 10\%$.

After some braking cycles, values of static braking torque could reduce by 5% and 10%, due to the adjustment of discs.

ATTENTION: always verify that the static braking torque M_{Bstat} referred to the gear reducer low speed shaft is lower than the value of M_{2MAX} allowed by the gear reducer itself.

Effects on the thermal power of the gear reducer

Generally, in the running conditions required by normal applications where an hydraulically released brake is present, the thermal power of the gear reducer is not exceeded.

Nevertheless, under some running conditions (high speed, continuous or frequent duty, unfavorable mounting position like V1 and V3 or similar) it is possible that the normal brake operation generate a progressive overheating of the group, influencing the thermal power allowed by the gear reducer.

In these cases it is possible to adopt solutions to reduce overheating of the brake or increase the thermal power of the group by means of an integrated cooling system or an independent cooling unit.

Consult us for further information.

Speed limits

The presence of a SAHR brake does not limit the values of n_{1max} and n_{1peak} of the gear reducer stated in EP catalog.

ATTENTION: a continuous or frequent duty at high speed may generate an overheating of the group (previous paragraph).

Operating conditions

Brakes are designed for industrial applications, at ambient temperature $-20\text{ }^{\circ}\text{C} \div +50\text{ }^{\circ}\text{C}$, maximum altitude 1 000 m. For operation at temperatures from $-20\text{ }^{\circ}\text{C}$ to $0\text{ }^{\circ}\text{C}$ limit p_{max} to 200 bar.

Lubrication of PB parking brakes

PB series brakes **require lubrication** and are supplied **without oil**, as specified by the relevant adhesive label.

Before putting the brakes into service fill them with mineral oil ISO VG 32, unless otherwise prescribed by specific documentation. Hydraulic oils are generally suitable.

The separate lubrication prevents premature lubricant contamination in the gear reducer, increasing gears and bearings life.



Functioning of PB parking brakes

Brake closed

When no pressure is applied to the brake (0 bar) springs (1) apply a force to the piston (2) which lock the discs (3) and produce a nominal braking torque equivalent to M_{Bstat} .

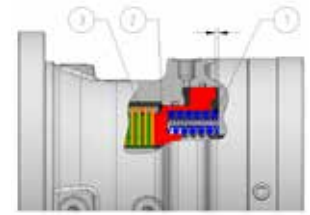

Brake opened

Above the pressure of 0 bar, the piston begins to compress the springs and the brake progressively reduces the braking torque.

When the release pressure exceeds the value of p_{min} the brake begins to open; once reached the value p the brake is fully opened, the piston ends its displacement and the discs can rotate freely.

To ensure a long life of the brake, it is suggested to use a release pressure 50% above the value of p and in any case not higher than p_{max} .

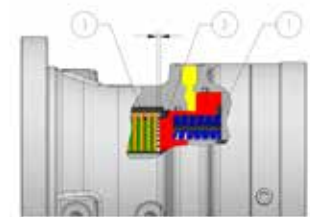

Brake release

To release the brake it is recommended the use of mineral-based hydraulic oil; synthetic oils may damage and cause malfunctions in the brake.

Connect the brake to the hydraulic circuit of machine through the brake release hole. Before first use it is necessary to bleed off.

Follow the instructions below:

- Slightly loosen the release fitting
- Release the brake at low pressure and wait for the complete bleeding off
- Tighten the release fitting

For further information refer to specific operating instructions manual.

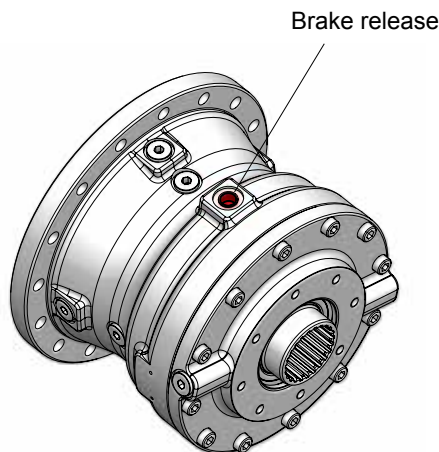

Technical data

PB10-...			0075	0150	0225	0340	0420	0525	0650	0815
Static braking torque	M_{Bstat}	[N m]	72	156	224	345	421	531	660	818
Min release pressure	p_{min}	[bar]	4,4	9,5	10,2	15,7	15,4	19,4	20,1	24,9
Release pressure	p	[bar]	6,9	14,9	16,1	24,7	24,2	30,4	31,6	39,1
Max release pressure	p_{max}	[bar]	300							
Maximum speed	n_{1max}	[min ⁻¹]	According to gear reducer n_{1max} and n_{1peak}							
Oil volume for brake release	V	[l]	0,10							

PB30-...			0250	0400	0500	0630	0800	1000	1250	1500	1700
Static braking torque	M_{Bstat}	[N m]	265	407	509	637	809	1010	1281	1529	1741
Min release pressure	p_{min}	[bar]	7,6	11,8	11,8	14,7	15,6	19,4	24,7	25,2	28,7
Release pressure	p	[bar]	12,0	18,5	18,5	23,1	24,5	30,5	38,7	39,6	45,1
Max release pressure	p_{max}	[bar]	300								
Maximum speed	n_{1max}	[min ⁻¹]	According to gear reducer n_{1max} and n_{1peak}								
Oil volume for brake release	V	[l]	0,12								

PB90-...			0850	1250	1500	1800	2100	2600	3000	3550	4250
Static braking torque	M_{Bstat}	[N m]	869	1304	1552	1811	2173	2680	3063	3560	4305
Min release pressure	p_{min}	[bar]	10,2	15,3	18,2	18,2	21,9	27,0	27,0	31,4	37,9
Release pressure	p	[bar]	15,3	23,0	27,4	27,4	32,8	40,5	40,5	47,1	56,9
Max release pressure	p_{max}	[bar]	300								
Maximum speed	n_{1max}	[min ⁻¹]	According to gear reducer n_{1max} and n_{1peak}								
Oil volume for brake release	V	[l]	0,25								

Different braking torques on request.

The above performances are provided with a back pressure equal to 0 bar, any counter pressures must be considered when sizing the system.

Dimensions

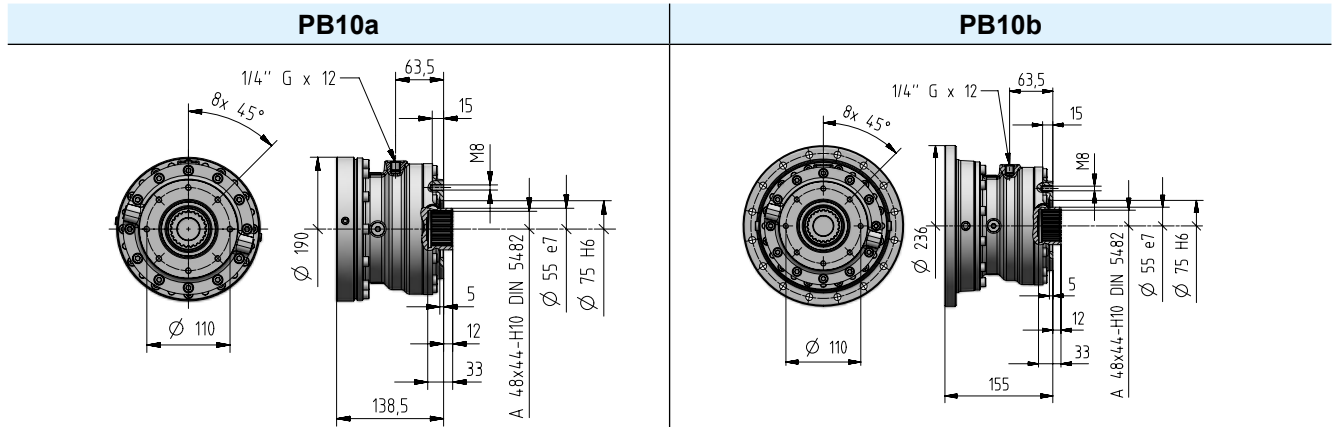

	1EL	2EL	3EL	4EL	2EB	3EB	4EB	
PB10a	001A, 002A	004A ... 007A	007A...021A	007A...060A	004A ... 007A	007A...021A	007A...060A	18
PB10b	004A ... 007A	015A, 021A	030A...060A	085A...180A	009A ... 015A	030A, 042A	085A, 125A	25

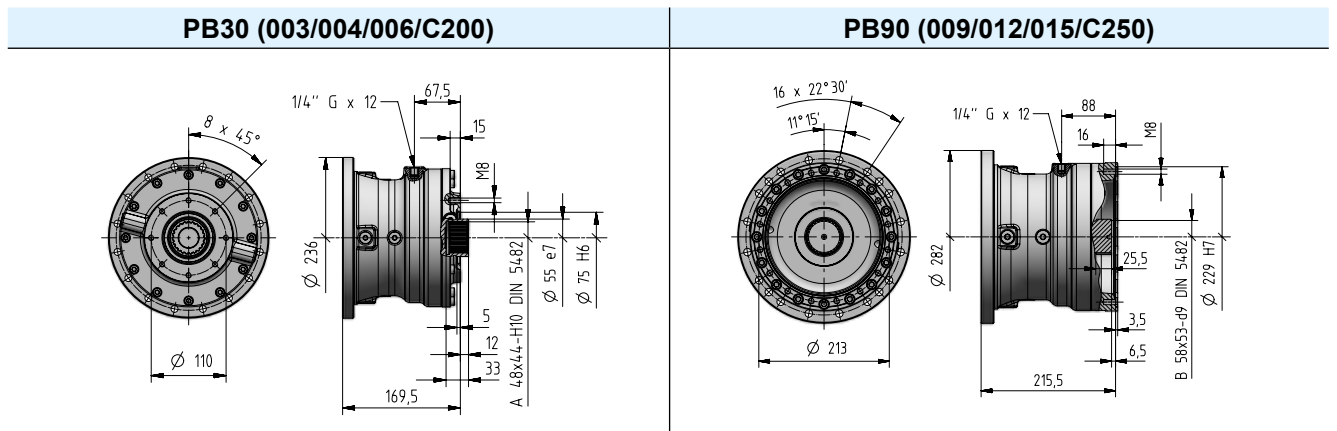

	1EL	2EL	3EL	4EL	2EB	3EB	4EB	
PB30	004A ... 007A	015A, 021A	030A...060A	085A...180A	015A	030A, 042A	085A, 125A	25
PB90	009A ... 015A	030A, 042A	085A, 125A	250A	018A ... 030A	060A, 085A	180A, 250A	53

IEC Electric motor adapters

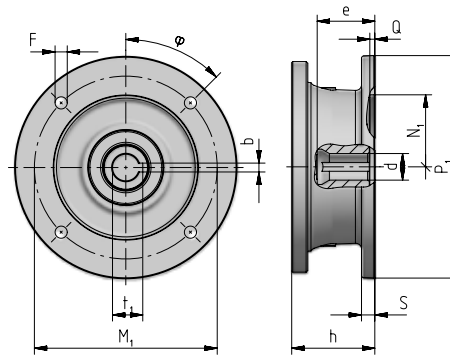

Motor size IEC	dxP	P Ø	S	d Ø	e max	b F9	t ₁	M ₁	F Ø	φ	N1 Ø G7	Q	Code
71	14x160	160	-	14 F6	32	5	16,3	130	M8x16 (n.4)	45°	110	4,5	I14x160
80	19x200	200	12	19 F6	41,5	6	21,8	165	11 (n.4)	45°	130	4,5	I19x200
90	24x200	200	12	24 F6	52	8	27,3	165	11 (n.4)	45°	130	4,5	I24x200
100	28x250	250	14	28 F6	62	8	31,3	215	14 (n.4)	45°	180	5	I28x250
112	28x250	250	14	28 F6	62	8	31,3	215	14 (n.4)	45°	180	5	I28x250
132	38x300	300	14	38 F6	82	10	41,3	265	14 (n.4)	45°	230	5	I38x300
160	42x350	350	15	42 F6	113	12	45,3	300	18 (n.4)	45°	250	6	I42x350
180	48x350	350	15	48 F6	113	14	51,8	300	18 (n.4)	45°	250	6	I48x350
200	55x400	400	15	55 E6	113	16	59,3	350	18 (n.4)	45°	300	6	I55x400
225	60x450	450	18	60 E6	143	18	64,4	400	18 (n.8)	22,5°	350	6	I60x450
250	65x550	550	18	65 E6	142	18	69,4	500	18 (n.8)	22,5°	450	6	I65x550
280	75x550	550	18	75 E6	142	20	79,9	500	18 (n.8)	22,5°	450	6	I75x550

Motor size IEC	h														
	007A			015A			021A			030A			042A		
	2EL	3EL	4EL	2EL	3EL	4EL	2EL	3EL	4EL	2EL	3EL	4EL	2EL	3EL	4EL
71	52	52	52	-	52	52	-	52	52	-	-	52	-	-	52
80	72	72	72	-	72	72	-	72	72	-	-	72	-	-	72
90	72	72	72	-	72	72	-	72	72	-	-	72	-	-	72
100	82	82	82	103	82	82	103	82	82	-	103	82	-	103	82
112	82	82	82	103	82	82	103	82	82	-	103	82	-	103	82
132	102	102	102	120	102	102	120	102	102	133,5	120	102	133,5	120	102
160	135	135	135	153	135	135	153	135	135	159	153	135	159	153	135
180	135	135	135	153	135	135	153	135	135	159	153	135	159	153	135
200	-	-	-	153	-	-	153	-	-	159	153	-	159	153	-
225	-	-	-	-	-	-	-	-	-	189	-	-	189	-	-
250	-	-	-	-	-	-	-	-	-	189	-	-	189	-	-
280	-	-	-	-	-	-	-	-	-	189	-	-	189	-	-

Motor size IEC	h														
	060A			085A			125A			180A			250A		
	2EL	3EL	4EL	2EL	3EL	4EL	2EL	3EL	4EL	2EL	3EL	4EL	2EL	3EL	4EL
71	-	-	52	-	-	-	-	-	-	-	-	-	-	-	-
80	-	-	72	-	-	-	-	-	-	-	-	-	-	-	-
90	-	-	72	-	-	-	-	-	-	-	-	-	-	-	-
100	-	103	82	-	-	103	-	-	103	-	-	103	-	-	-
112	-	103	82	-	-	103	-	-	103	-	-	103	-	-	-
132	-	120	102	-	133,5	120	-	133,5	120	-	-	120	-	-	133,5
160	159	153	135	111	159	153	111	159	153	-	159	153	-	111	159
180	159	153	135	111	159	153	111	159	153	-	159	153	-	111	159
200	159	153	-	111	159	153	111	159	153	-	159	153	-	111	159
225	189	-	-	141	189	-	141	189	-	-	189	-	-	141	189
250	189	-	-	141	189	-	141	189	-	-	189	-	-	141	189
280	189	-	-	141	189	-	141	189	-	-	189	-	-	141	189

Universal flange adapter

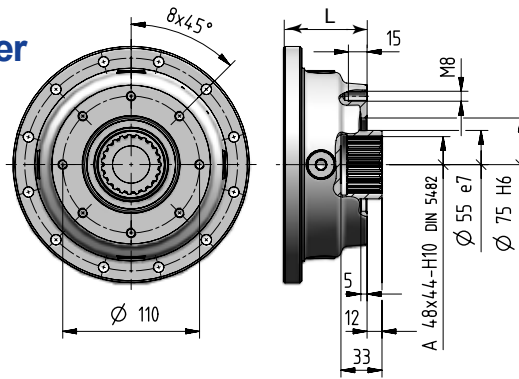

U	007A			015A			L			021A			030A			042A		
	2EL	3EL	4EL	2EL	3EL	4EL	2EL	3EL	4EL	2EL	3EL	4EL	2EL	3EL	4EL	2EL	3EL	4EL
	64	64	64	62	64	64	62	64	64	-	62	64	-	62	64	-	62	64

U	060A			085A			L			125A			180A			250A		
	2EL	3EL	4EL	2EL	3EL	4EL	2EL	3EL	4EL	2EL	3EL	4EL	2EL	3EL	4EL	2EL	3EL	4EL
	-	62	64	-	-	62	-	-	62	-	-	62	-	-	62	-	-	-

The universal input flange allows the customers to make their flanges and couplings suitable for the main motorization types. It's very important to observe the information shown in the drawing below to obtain a correct gear reducer oil sealing. The universal input flange can be used for motors up to 1 000 Nm maximum torque and weight as per following chart.

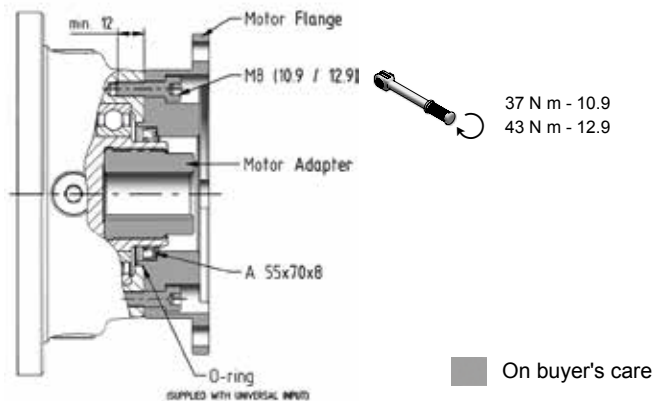

Gearboxes with "U" input (not "UN" and "UH") are supplied with an additional cover as shown below. When a flange made by customer have to be used, please remove it.

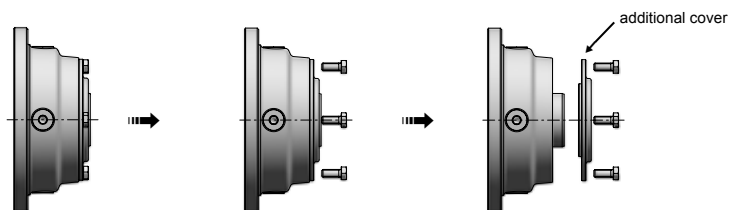

When a universal flange adapter is used, it must be checked if the total weight of the flange+motor and the distance of their center of gravity are compliant with the following diagram.

In case of high vibrations or dynamic stress, please contact Rossi S.p.A.

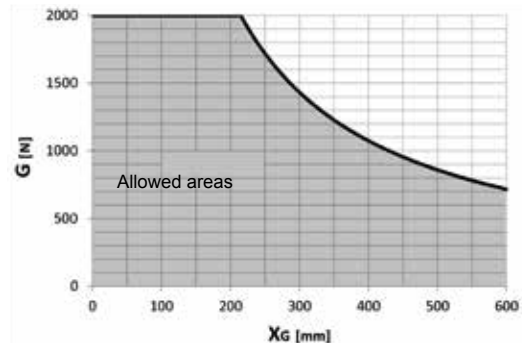
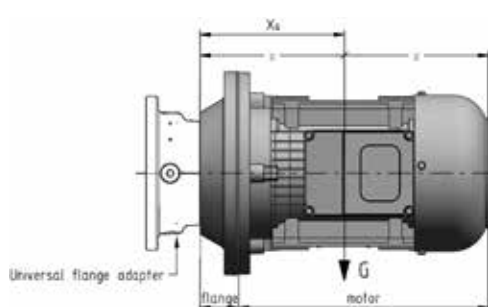

NEMA motor input flanges

The available NEMA motor adaptors are shown in the tables below. They are suitable for NEMA C-FACE frame. Other sizes are available on request.

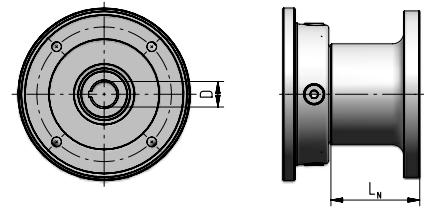

Size	NEMA D Code Dimension	143/145 TC 22,23 (7/8") UN N14 L _N	182/184 TC 28,58 (1-1/8") UN N18 L _N	213/215 TC 34,93 (1-3/8") UN N21 L _N	254/256 TC 41,28 (1-5/8") UN N25 L _N	284/286 TC 47,63 (1-7/8") UN N28 ¹⁾ L _N
001A - 007A	1EL ... 4EL 2EB ... 4EB	34	50	116,5	116,5	132
009A - 015A	2EL ... 4EL 2EB ... 4EB	34	50	116,5	116,5	132
018A, 021A	2EL ... 4EL 3EB, 4EB	34	50	116,5	116,5	132
030A, 042A	3EL, 4EL 3EB, 4EB	34	50	116,5	116,5	132
060A	3EL, 4EL 4EB	34	50	116,5	116,5	132
085A ... 180A 085A ... 125A	4EL 4EB	34	50	116,5	116,5	132

1) To be used in vertical position, only.

Details

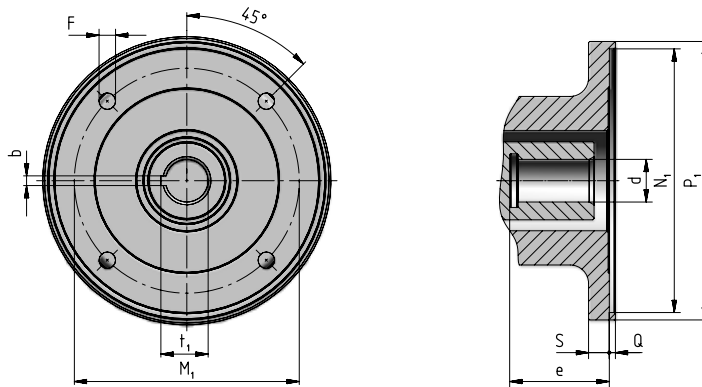

NEMA C-face	P ₁ Ø	S	d Ø E6	e	b 0 / +0,050	t ₁ 0 / +0,100	M ₁	F	N ₁ Ø H7	Q	Code	kg
143/145 TC	168	9	22,23 (7/8")	50	4,78 (3/16")	24,4	149,22 (5-7/8")	10,5	114,3 (4-1/2")	5	UN N14	3.4
182/184 TC	228	16	28,58 (1-1/8")	71	6,35 (1/4")	31,5	184,15 (7-1/4")	13,5	215,9 (8-1/2")	5	UN N18	8
213/215 TC	228	17	34,93 (1-3/8")	81,5	7,94 (5/16")	38,7	184,15 (7-1/4")	13,5	215,9 (8-1/2")	5	UN N21	14.3
254/256 TC	228	17	41,28 (1-5/8")	97,5	9,53 (3/8")	45,6	184,15 (7-1/4")	13,5	215,9 (8-1/2")	5	UN N25	14.2
284/286 TC	277	17	47,63 (1-7/8")	113	12,7 (1/2")	53,2	228,6 (9")	13,5	266,7 (10-1/2")	5	UN N28	17.9

Hydraulic motor input flange dimensions

The available hydraulic motor adapters are shown in the tables below. It's important to always check the coupling dimensions shown in the following pages. Lots of alternative solutions are available on request.

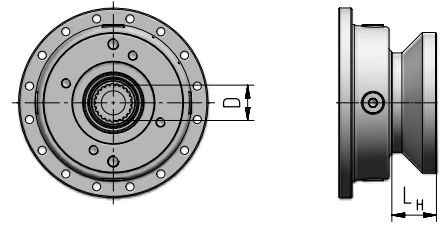

Brand	Model Size D Code	PARKER dimension L _H																				
		F11			F12						TE-TJ-TF					TF-TG						
		10 - 19 16/32-13T UH SB3	14 - 19 25,4 UH SB13	30 25,4 UH SB13	30 16/32-13T UH SB3	30 30x2x14 UH IB1	40 - 60 31,75 UH SC6	40 - 60 12/24-14T UH SC4	60 35x2x16 UH IC2	90 40 UH ID4	90 12/24-17T UH SC5	90 40x2x18 UH ID2	125 45x2x21 UH IE1	- 25 UH SA1	- 25,4 UH SA11	- 25,4 UH SA13	- 1" 6B UH SA10	- 1" 6B UH SA2	- 31,75 UH SA12	- 31,75 UH SA6	- 32 UH SA5	- 12/24-14T UH SA4
001A ... 007A	1EL ... 4EL 2EB ... 4EB	56	48	48	56	42	39,5	39,5	53	128	39,5	98	111	35	47	47	35	35	47	47	47	47
009A ... 015A	2EL ... 4EL 2EB ... 4EB	56	48	48	56	42	39,5	39,5	53	128	39,5	98	111	35	47	47	35	35	47	47	47	47
018A ... 021A	2EL ... 4EL 3EB, 4EB	56	48	48	56	42	39,5	39,5	53	128	39,5	98	111	35	47	47	35	35	47	47	47	47
022A	2EL ... 4EL 2EB ... 4EB	56	48	48	56	42	39,5	39,5	53	128	39,5	98	111	35	47	47	35	35	47	47	47	47
030A ... 042A	3EL, 4EL 3EB, 4EB	56	48	48	56	42	39,5	39,5	53	128	39,5	98	111	35	47	47	35	35	47	47	47	47
060A	3EL, 4EL 4EB	56	48	48	56	42	39,5	39,5	53	128	39,5	98	111	35	47	47	35	35	47	47	47	47
085A ... 180A 085A ... 125A	4EL 4EB	56	48	48	56	42	39,5	39,5	53	128	39,5	98	111	35	47	47	35	35	47	47	47	47

Brand	Model Size D Code	BOSCH REXROTH dimension L _H												
		A2FM												
		56,63 35x2x16 UH IC2	80,90 40 UH ID4	80,90 35x2x16 UH ID1	80,90 40x2x18 UH ID2	107,125 45x2x21 UH IE1	160,180 50x2x24 UH IF1	10,12,16 20 UH IA1	10,12,16 25 UH IA2	10,12,16 20x1,25x14 UH IA3	10,12,16 25x1,25x18 UH IA4	23,28,32 25 UH IB6	23,28,32 30x2x14 UH IB1	45,56 30x2x14 UH IC1
001A ... 007A	1EL ... 4EL 2EB ... 4EB	53	128	53	98	111	116	40	40	40	40	54,5	42	53
009A ... 015A	2EL ... 4EL 2EB ... 4EB	53	128	53	98	111	116	40	40	40	40	54,5	42	53
018A ... 021A	2EL ... 4EL 3EB, 4EB	53	128	53	98	111	116	40	40	40	40	54,5	42	53
022A	2EL ... 4EL 2EB ... 4EB	53	128	53	98	111	116	40	40	40	40	54,5	42	53
030A ... 042A	3EL, 4EL 3EB, 4EB	53	128	53	98	111	116	40	40	40	40	54,5	42	53
060A	3EL, 4EL 4EB	53	128	53	98	111	116	40	40	40	40	54,5	42	53
085A ... 180A 085A ... 125A	4EL 4EB	53	128	53	98	111	116	40	40	40	40	54,5	42	53

Brand	Model Size D Code	EATON dimension L _H							
		2000				4000			
		80 - 490 25,4 UH SA11	80 - 490 31,75 UH SA12	80 - 490 31,75 UH SB12	80 - 490 32 UH SA5	80 - 490 12/24-14T UH SA4	110 - 625 31,75 UH SB14	110 - 625 31,75 UH SB14	110 - 625 12/24-17T UH SC5
001A ... 007A	1EL ... 4EL 2EB ... 4EB	47	47	48	47	47	56	47	
009A ... 015A	2EL ... 4EL 2EB ... 4EB	47	47	48	47	47	56	47	
018A ... 021A	2EL ... 4EL 3EB, 4EB	47	47	48	47	47	56	47	
022A	2EL ... 4EL 2EB ... 4EB	47	47	48	47	47	56	47	
030A ... 042A	3EL, 4EL 3EB, 4EB	47	47	48	47	47	56	47	
060A	3EL, 4EL 4EB	47	47	48	47	47	56	47	
085A ... 180A 085A ... 125A	4EL 4EB	47	47	48	47	47	56	47	

Brand	Model Size D Code	WHITE HYDRAULICS dimension L _H							
		RS		HB					
		200 - 201 25,4 UH SB13	300 25 UH SA1	300 25,4 UH SA13	300 25,4 UH SB13	300 31,75 UH SA6	300 31,75 UH SB12	300 1" 6B UH SA2	300 16/32-13T UH SB11
001A ... 007A	1EL ... 4EL 2EB ... 4EB	48	35	47	48	47	48	35	56
009A ... 015A	2EL ... 4EL 2EB ... 4EB	48	35	47	48	47	48	35	56
018A ... 021A	2EL ... 4EL 3EB, 4EB	48	35	47	48	47	48	35	56
022A	2EL ... 4EL 2EB ... 4EB	48	35	47	48	47	48	35	56
030A ... 042A	3EL, 4EL 3EB, 4EB	48	35	47	48	47	48	35	56
060A	3EL, 4EL 4EB	48	35	47	48	47	48	35	56
085A ... 180A 085A ... 125A	4EL 4EB	48	35	47	48	47	48	35	56

Brand	Model Size D Code	SAUER DANFOSS dimension L _H						
		OMP - OMR			OMH - OMS		OMT	
		25 - 400 25 UH SA1	25 - 400 25,4 UH SA11	25 - 400 32 UH SA5	25 - 400 1" 6B UH SA10	80 - 500 32 UH SA5	81 - 500 12/24-14T UH SA4	160 - 500 40 UH IC3
001A ... 007A	1EL ... 4EL 2EB ... 4EB	35	47	47	35	47	47	135
009A ... 015A	2EL ... 4EL 2EB ... 4EB	35	47	47	35	47	47	135
018A ... 021A	2EL ... 4EL 3EB, 4EB	35	47	47	35	47	47	135
022A	2EL ... 4EL 2EB ... 4EB	35	47	47	35	47	47	135
030A ... 042A	3EL, 4EL 3EB, 4EB	35	47	47	35	47	47	135
060A	3EL, 4EL 4EB	35	47	47	35	47	47	135
085A ... 180A 085A ... 125A	4EL 4EB	35	47	47	35	47	47	135

Brand	Model Size D Code	SAI dimension L _H	
		GM	
		1 28 UNI 221 UH M11	05 28 UNI 221 UH M01
001A ... 007A	1EL ... 4EL 2EB ... 4EB	22	40
009A ... 015A	2EL ... 4EL 2EB ... 4EB	22	40
018A ... 021A	2EL ... 4EL 3EB, 4EB	22	40
022A	2EL ... 4EL 2EB ... 4EB	22	40
030A ... 042A	3EL, 4EL 3EB, 4EB	22	40
060A	3EL, 4EL 4EB	22	40
085A ... 180A 085A ... 125A	4EL 4EB	22	40

Similar to SAE J744c (SAE - A) standards

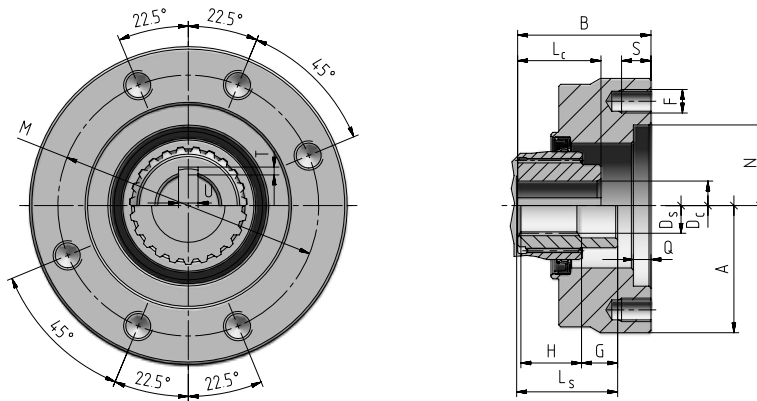

A	B	N	D _c	D _s	F	G	H	L _c	L _s	S	Q	M	U	T	Code	kg
∅		G7 ∅	∅	∅												
130	56	82,55	25	E8	-	-	-	42,5	-	15	9	106,4	8	3,2	UH SA1	2,7
130	56	82,55	-	-	M12	0	29	-	29	15	9	106,4	-	-	UH SA2	2,6
130	68	82,55	-	-	M12	19	32	-	51	15	9	106,4	-	-	UH SA4	3,6
130	68	82,55	32	G7	-	-	-	55,5	-	15	9	106,4	10	3,4	UH SA5	3,6
130	68	82,55	31,75	G6	-	-	-	51	-	15	9	106,4	8	3,4	UH SA6	3,6
130	56	82,55	-	-	M12	0	25	-	25	15	9	106,4	-	-	UH SA10	2,6
130	68	82,55	25,4	E6	-	-	-	53	-	15	9	106,4	6,38	3	UH SA11	3,7
130	68	82,55	31,75	G6	-	-	-	56	-	15	9	106,4	8	3,8	UH SA12	3,7
130	68	82,55	25,4	E6	-	-	-	58	-	15	9	106,4	6,38	3	UH SA13	3,8

Similar to SAE J744c (SAE - B) standards

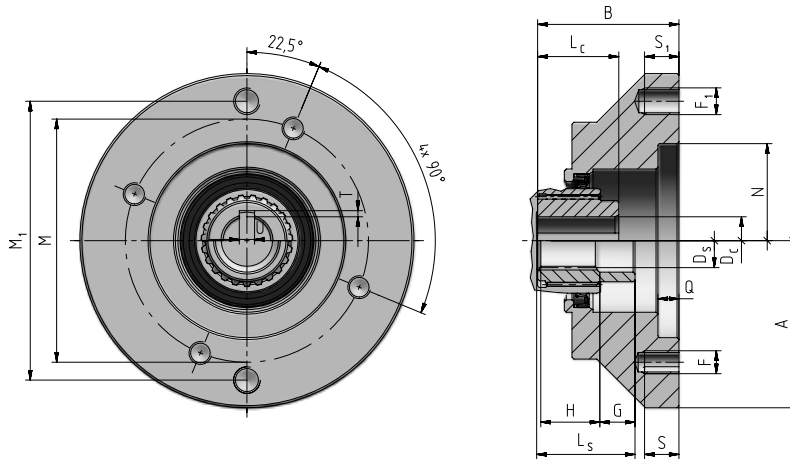

A	B	N	D _c	D _s	F	F ₁	G	H	L _c	L _s	S	S ₁	Q	M	M ₁	U	T	Code	kg	
∅		H6 ∅	∅	∅																
175	77	101,6	-	-	M12	M14	-	31	-	67	18	18	11	127,3	146	-	-	UH SB3	6,3	
175	77	101,6	-	-	M12	M14	-	31	-	47	18	18	11	127,3	146	-	-	UH SB11	6,1	
175	69	101,6	31,75	G6	-	-	-	56	-	-	18	18	11	127,3	146	8	3,8	UH SB12	5,5	
175	69	101,6	25,4	E6	-	-	-	58	-	-	18	18	11	127,3	146	6,38	3	UH SB13	5,7	
175	77	101,6	31,75	G6	-	-	-	56	-	-	18	18	11	127,3	146	8	3,8	UH SB14	6,0	

Similar to SAE J744c (SAE - C) standards

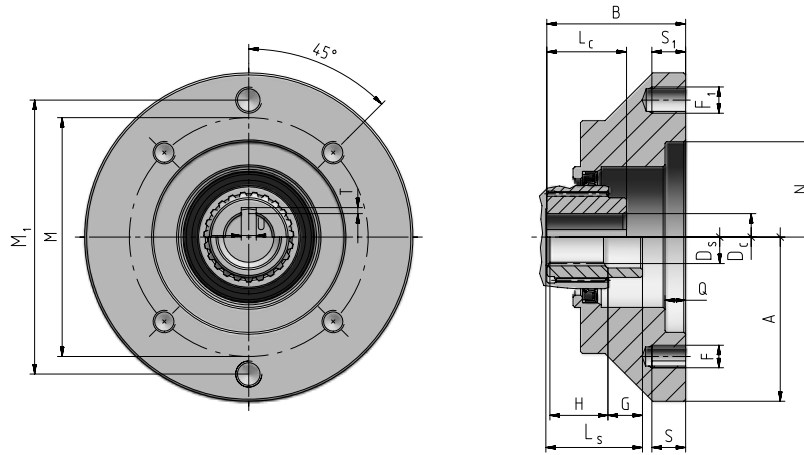

A	B	N	D _c	D _s	F	F ₁	G	H	L _c	L _s	S	S ₁	Q	M	M ₁	U	T	Code	kg
∅		G7 ∅	∅	∅															
207	60,5	127	-	12/24-14T	M14	M16	19	32	-	51	15	15	17,5	162	181	-	-	UH SC4	4
207	68	127	-	12/24-17T	M14	M16	-	30	-	30	15	15	17,5	162	181	-	-	UH SC5	4
207	60,5	127	31,75 G6	-	M14	M16	-	-	51	-	15	15	17,5	162	181	8	3,8	UH SC6	4

Similar to ISO 3019-2 standards

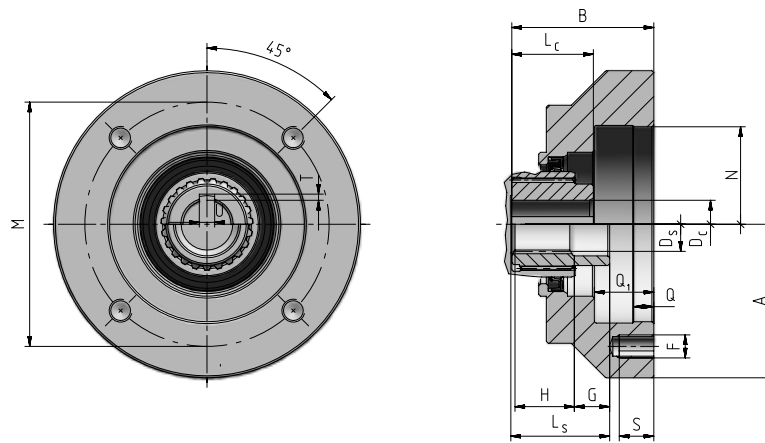

A	B	N	D _c	D _s	F	G	H	L _c	L _s	S	Q	Q ₁	M	U	T	Code	kg
∅		∅	∅	DIN 5480 ∅													
130	61	80	H7	20 E6	-	M8	-	40	-	20	7	20	100	6	2,8	UH IA1	3,2
130	61	80	H7	25 E6	-	M8	-	40	-	20	7	20	100	8	3,3	UH IA2	3,2
130	61	80	H7	-	20×1,25×14	M8	11	24	-	40	7	20	100	-	-	UH IA3	3,2
130	61	80	H7	-	25×1,25×18	M8	5	24	-	40	7	20	100	-	-	UH IA4	3,2
149	63	100	H6	-	30×2×14	M10	-	35	35	15	9	25	125	-	-	UH IB1	3,2
149	63	100	H6	25 E6	-	M10	-	50	-	15	9	25	125	8	3,3	UH IB3	3,4
149	75,5	100	H6	25 E6	-	M10	-	50	-	15	9	25	125	8	3,3	UH IB6	4,3
179	74	125	H6	-	30×2×14	M12	-	35	35	25	8	31,5	160	-	-	UH IC1	4,6
179	74	125	H6	-	35×2×16	M12	-	40	40	25	8	31,5	160	-	-	UH IC2	4,6
184	115	125	H6	40 H6	-	M12	-	78	-	18	10	51	160	12	3,3	UH IC3	16,5
206	74	140	H7	-	35×2×16	M12	-	40	40	15	11	29	180	-	-	UH ID1	4,7
206	78,5	140	H7	-	40×2×18	M12	-	37,5	37,5	15	11	29	180	-	-	UH ID2	14,7
206	108	140	H7	40 H6	-	M12	-	78	-	15	11	29	180	12	3,3	UH ID4	11,9
238	91	160	G7	-	45×2×21	M16	-	42	42	24	12	40	200	-	-	UH IE1	12,6
257	96	180	H7	-	50×2×24	M16	-	44	44	26	11	40	224	-	-	UH IF1	26

Flanges for SAI motors

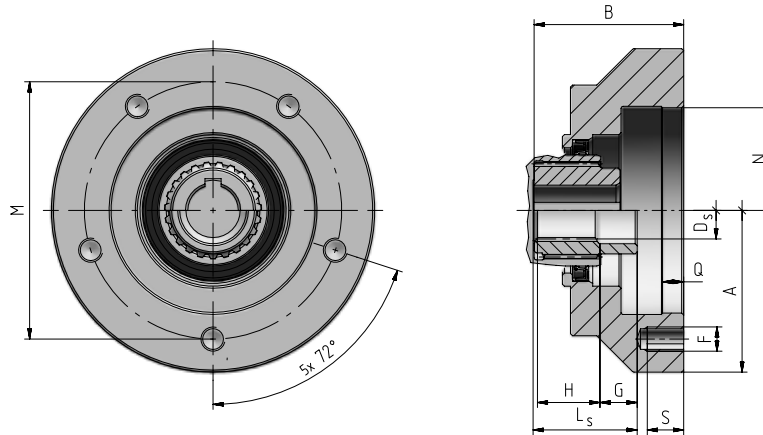

A	B	N	D _s	F	G	H	L _s	S	Q	M	Code	kg
179	61	125	28 UNI 221	M10	10	22	32	12	14	160	UH M01	3,1
229	43	175	28 UNI 221	M12	10	22	32	15	6	210	UH M11	4,2

Installation

To ensure proper functioning and optimum transfer of power between the gear reducer and the driven gear, the gear reducer requires a rigid connection construction that is resistant to torsion. The form and position tolerances listed below must be met.

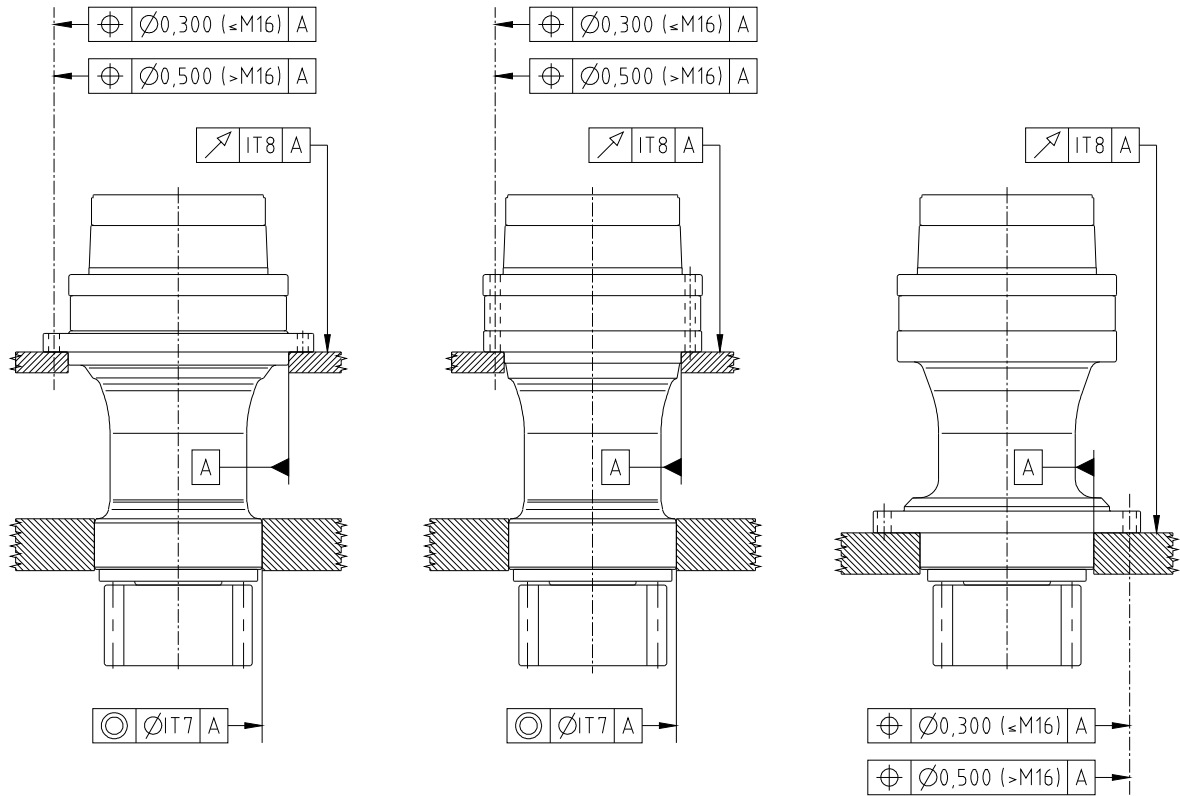

Screws and tightening torques

According to the design and size stated on nameplate, use screws and tightening torques as shown in the following tables; at least class 10.9 is necessary but in case of heavy stresses, alternate loads and shocks use class 12.9. Screws of class 12.9 must be equipped (where indicated, e.g.:  see following table) with ISO 7089 washers (300 HV min.).

Be careful to the tightening of the 12.9 screws. Over tightening can damage them.

The suggested tightening torque value are valid for an estimated friction coefficient of $\mu = 0,14$ typical for lightly oiled steel bolts, black annealed or phosphatised and dry, cut mating threads in steel or cast iron.

Do not use lubricants altering the friction coefficient for they may overload the screw connection.

Always use dynamometric wrench or similar and verify the tightening torque after the first hours of running.

Tightening torque [N m]

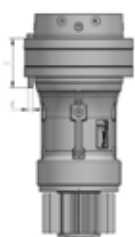
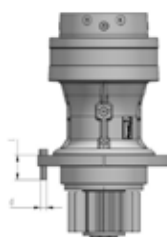
R					S				H			
												
size	output design	n	d	l min	output design	n	d	l min	output design	n	d	l min
007A	R30b	12	M12	50	S30b	16	M10	100	H30b	10	M16	60
015A	R30c	10	M16	60	S30c	16	M12	130	H30c	12	M16	55
021A	R30d	24	M16	65	S30d	16	M14	140	H30d	12	M20	70
030A	R30e	24	M16	65	S30e	24	M16	160	H30e	24	M20	80
042A	R30f	24	M20	70	S30f	28	M16	180	H30f	24	M20	70
060A	R30g	24	M20	80	S30g	24	M20	220	H30g	24	M20	80
085A	R30h	24	M20	80	S30h	28	M20	240	H30h	24	M30	110
125A	R30i	24	M24	90	S30i	28	M24	240	H30i	28	M24	90
180A	R30j	28	M24	90	S30j	32	M24	260	H30j	32	M24	90
250A	R30k	28	M30	110	S30k	28	M30	300	H30k	28	M30	110

Tightening torque [N m]



Ø	8.8	10.9	Class
	$M_2 < 70\% M_{r2}$		12.9 Washer must be always used (300 HV min.)
M10	50	70	85
M12	85	120	145
M14	135	190	230
M16	210	300	355
M20	400	560	675
M22	530	770	895
M24	690	1000	1165
M27	1010	1400	1705
M30	1380	1950	2330
M33	2000	2800	3375
M36	2500	3550	4220
M39	2950	4200	4980
M42	4100	5800	6920
M45	5000	7100	8440
M52	7600	10700	12800
M56	9800	13800	16540

Lubrication

Gear pairs are oil-bath lubricated, bearings are either oil bathed or splashed or lubricated for life with grease.

For some mounting positions with continuous duty at high speed, an expansion tank could be required: consult us.

Sizes 007A ... 021A: gear reducers are supplied **filled with PAO synthetic oil** having ISO viscosity grade 320 cSt (at 40° C).

Important! Verify the mounting position, keeping in mind that if gear reducer is installed in a mounting position differing from the one stated on name plate, it could need the addition of the difference between the two lubricant quantities.

In any case, always check the correct oil quantities through the level plug.

Sizes 030A ... 250A: gear reducers are supplied **without oil**; before putting into service, fill to the specified level with synthetic or mineral oil (see table below).

The main lubricant manufacturers as well as the ISO viscosity grade to be used are stated in the following tables.

Use only lubricants with **EP** (extreme pressure) **additives**. In case of mineral lubricant choice, follow the instructions about the service factor (EP catalog).

Manufacturer	PAO synthetic oil ISO VG 320	Mineral oil ISO VG 150...460
ADDINOL	Eco Gear S	Eco Gear M
AGIP	Blasia SX	Blasia
ARAL	Degol PAS	Degol BG
BP	Enersyn EPX	Energol GR XP
CASTROL	Alphasyn T	Alpha SP
KLÜBER	Klübersynth GEM4	Klüberoil GEM1
MOBIL	Mobil SHC Gear	Mobilgear 600 XP
SHELL	Omala S4 GX	Omala S2 G
TOTAL	Carter SH	Carter EP

Lubricant

Lubricant type and viscosity selection according to output speed n_2 [min⁻¹] and ambient temperature T_{amb} [°C] range.

The following tables have been created starting from Shell lubricant characteristics, but are also valid for similar products (see table on page 8.23). For further verification, especially under extreme operating conditions, always refer to the technical data sheet of the specific lubricant.

Splash lubrication or with independent cooling units ¹⁾

	Oil viscosity [cSt @ 40°C]	Ambient temperature T_{amb} [°C]													
		-20	-15	-10	-5	0	+5	+10	+15	+20	+25	+30	+35	+40	+45
Mineral oil	ISO VG 150	$n_2 > 140$													
	ISO VG 220	$2,0 \leq n_2 \leq 140$													
	ISO VG 320	$n_2 < 2,0$													
	ISO VG 460	$n_2 < 2,0$													
PAO synthetic oil (Polyalphaolefine)	ISO VG 150	$n_2 > 140$													
	ISO VG 220	$2,0 \leq n_2 \leq 140$													
	ISO VG 320	$n_2 < 2,0$													
	ISO VG 460	$n_2 < 2,0$													
PAG synthetic oil (Poly Alkylene Glycol)	ISO VG 150	$n_2 > 140$													
	ISO VG 220	$2,0 \leq n_2 \leq 140$													
	ISO VG 320	$n_2 < 2,0$													
	ISO VG 460	$n_2 < 2,0$													

1) Provide starting of the independent cooling units only when the oil temperature T_{oil} is $> 25^\circ\text{C}$. During the starting, it may take a short period of time for the oil to circulate completely between the unit and the gearbox, depending on the viscosity level and the morphology of pipes and oil connections. During this transitional period, operation of the gear unit is permitted.

Forced lubrication with/without heat exchanger ²⁾

	Oil viscosity [cSt @ 40°C]	Ambient temperature T_{amb} [°C]												
		-20	-15	-10	-5	0	+5	+10	+15	+20	+25	+30	+35	+40
Mineral oil	ISO VG 150	$n_2 > 140$												
	ISO VG 220	$2,0 \leq n_2 \leq 140$												
	ISO VG 320	$n_2 < 2,0$												
	ISO VG 460	$2,0 \leq n_2 \leq 140$												
PAO synthetic oil (Polyalphaolefin)	ISO VG 150	$n_2 > 140$												
	ISO VG 220	$n_2 > 140$												
	ISO VG 320	$2,0 \leq n_2 \leq 140$												
	ISO VG 460	$2,0 \leq n_2 \leq 140$												
PAG synthetic oil (Poly Alkylene Glycol)	ISO VG 150	$n_2 > 140$												
	ISO VG 220	$n_2 > 140$												
	ISO VG 320	$2,0 \leq n_2 \leq 140$												
	ISO VG 460	$n_2 < 2,0$												

2) In the case of forced lubrication, the gear unit should only be operated when the oil temperature T_{oil} is higher than the temperature indicated in the table. During start-up of the lubrication unit, a short period of preheating may be necessary, to be carried out with the gear unit at standstill, before complete circulation of the oil and proper lubrication of the internal components is achieved.

- Admitted application field, optimal range.
- Admitted application field where higher absorption is expected due to higher viscosity; prefer gradual starts and partial load operation.
- Non-optimal application range; in this case it is recommended to use oils with viscosity grade at least 30 cSt referred to max oil temperature (T_{oil}) during the operation.
- Non-optimal application range; in this case it is necessary to foresee oil with Pour Point at least 10°C lower than the minimum temperature indicated by the field. Foresee a phase of rotation at no load (pre-heating) at least up to the attainment of a temperature T_{amb} equal or superior to the minimum indicated in the field of application admitted.
- Application field not allowed. If necessary contact Rossi S.p.A.
- $n_2 > 140$ Indicative output speed for selection of lubricant viscosity

Consider the lubrication interval stated in the table for all re-lubrication operations, emptying the gear reducers from the exhausted oil, executing a wash with clean oil of the same type to be used also for the re-filling of the gear reducer up to level.

Use only lubricants of the same type stated on lubrication nameplate.

Oil temperature [°C]	Oil-change interval [h]	
	Synthetic oil	Mineral oil
≤ 65	12 500	5 600
65 ÷ 80	10 000	2 800
80 ÷ 95	6 300	1 400

Oil-change intervals assume pollution-free surroundings. When heavy overloads are present, halve the values.

Independently from running times, change the oil:

every 2 ÷ 4 years, for synthetic oil;

every 1 ÷ 2 years, for mineral oil;

Never mix different makes of synthetic oil; if oil-change involves switching to a type different from that used hitherto, then give the gear reducer a through clean-out. Polyglycol basis synthetic lubricants must not be used.

Output seals and bearing are lubricated with grease. Re-grease every 5 600 h or once a year by using the greaser provided.

Bearings with independent lubrication

Usually the bearings are automatically and continuously lubricated (oil-bathed or splashed) with the same lubricant of gear reducer. However for certain gear reducer in vertical mounting positions the upper bearings have independent lubrication, with special grease for long life lubrication in absence of external pollution.

Multi-disc parking brakes lubrication

See chapter 6 Multi-disc parking brakes.

Customer :

Application description:

Mechanism (FEM 1.001 1998.10.01):

FEM Class: **M** _____
 Load Spectrum Class: **L** _____
 Running time Class: **T** _____

Gear reducer output torque and speed:

Output torque $M_{2required}$ _____ [N m]
 Has γ_m factor been included in $M_{2required}$ yes no
 Maximum output torque M_{2max} _____ [N m]
 Output speed n_2 _____ [min⁻¹]

Relevant Geometry (please fill-out relevant dotted lines):

Type H

Type R

Type S

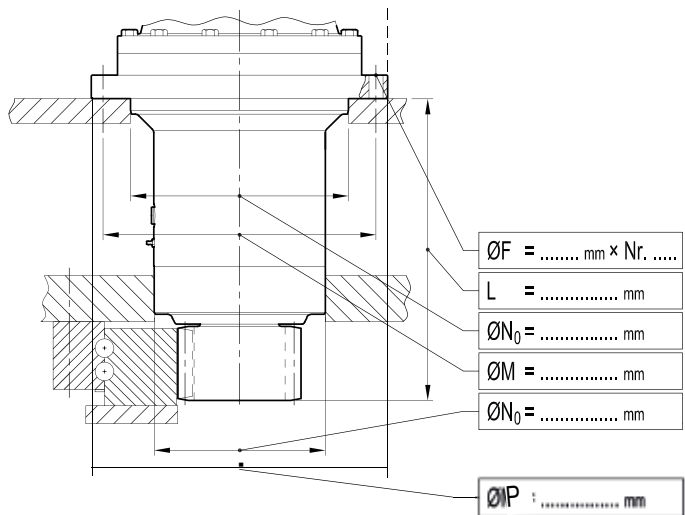
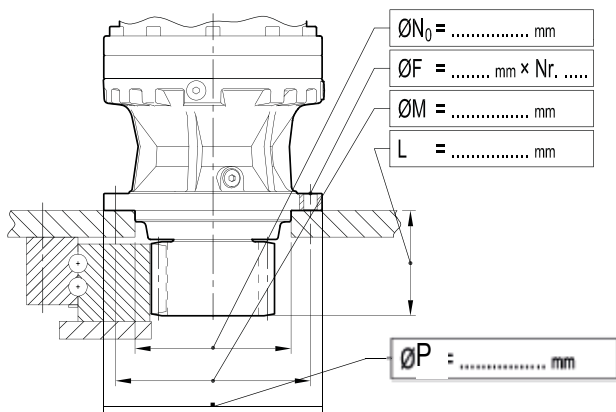

Excentricity is required yes no

If yes, state the value **E** _____ mm

Mounting positions

B5

V1

V3

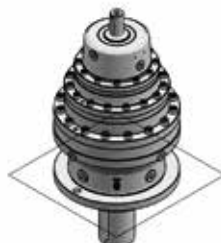

UTC 1474

Pinion / Slew Ring data:

Centre distance (Pinion - Slew Ring) a: _____ [mm]

Pinion One piece solid
 Fitted on splined shaft

Slew Ring (Ring Bearing) Internal toothing
 External toothing

For information only

m modulus _____ [mm]

m modulus _____ [mm]

Z₁ N°. of teeth _____ [-]

Z₂ N°. of teeth _____ [-]

x·m profile correction _____ [mm]

x·m profile correction _____ [mm]

Profile modification yes no

b₂ facewidth _____ [mm]

b₁ facewidth _____ [mm]

Material _____

Material high alloy steel tempered
 high alloy steel case hardened

Heat treatment _____

other _____

Hardness _____

Hardness _____

Electric Motor:

Power: _____ [kW]; Voltage: _____ [V]; Frequency: _____ [Hz]; N° poles: _____ [-];

Frequency Control device: yes no

Motor brake: yes no

If equipped with brake: Static braking torque: _____ [N m]

Parking Brake: yes no

If parking brake required Static braking torque: _____ [N m]

Hydraulic Motor:

Brand and type: _____

Displacement: _____ [cc]; Max pressure: _____ [MPa]; Working pressure: _____ [MPa];

Motor interface dimensions: _____

Notes and Remarks: _____

Rossi for You



Innovation

Rossi S.p.A. offers a wide range of solutions for an evolving industry, flexible and innovative gear reducers and gearmotors for customer tailored solutions to maximize performances and minimize the Total Cost of Ownership (TCO).



High quality, 3 years warranty

Our drive is to innovate and boost operations by manufacturing performing, precise, reliable and high-quality products all over the world. We are always one step forward in offering and developing solutions that can satisfy an unlimited number of application needs, even in the most demanding conditions.



Reliability

We are a reliable company with the right flexibility and know-how to respond to worldwide market requests, in all application fields, without leaving aside our commitment for the environment and value on human safety, to protect everyone's future.



Tools and processes

We continue to invest in new tools and processes, so our highly skilled specialist team in different fields are supporting you to find the best solution suitable for your demands, always by your side on every step of the project.



After-sale service

Highly trained mechanics and support teams can ensure a fast and efficient after-sale service providing support worldwide.



Digital support

Alongside our 24/7 Rossi for You portal you have a suite of digital support tools enabling real time access to your order tracking, invoices, spare part tables download and contact to our service.

70
YEARS

Experience

Shaped by 70 years of history Rossi meets your unique needs whether you need a standard design or a customized solution.



Global presence local service



Local support

Sales, customer service,
technical support, spare parts



17 branches*



Worldwide distribution network*

A global network of subsidiaries and dealers. From design and execution to after-sales service. Rossi is always close to you: a local, reliable and flexible partner.

Alongside our 24/7 **Rossi for You** portal you have a suite of digital support tools enabling real time access to your order tracking, invoices, spare part tables download and contact to our service.

*All contacts available on www.rossi.com





Main offices



Affiliated companies



Production facilities/Assembly plants

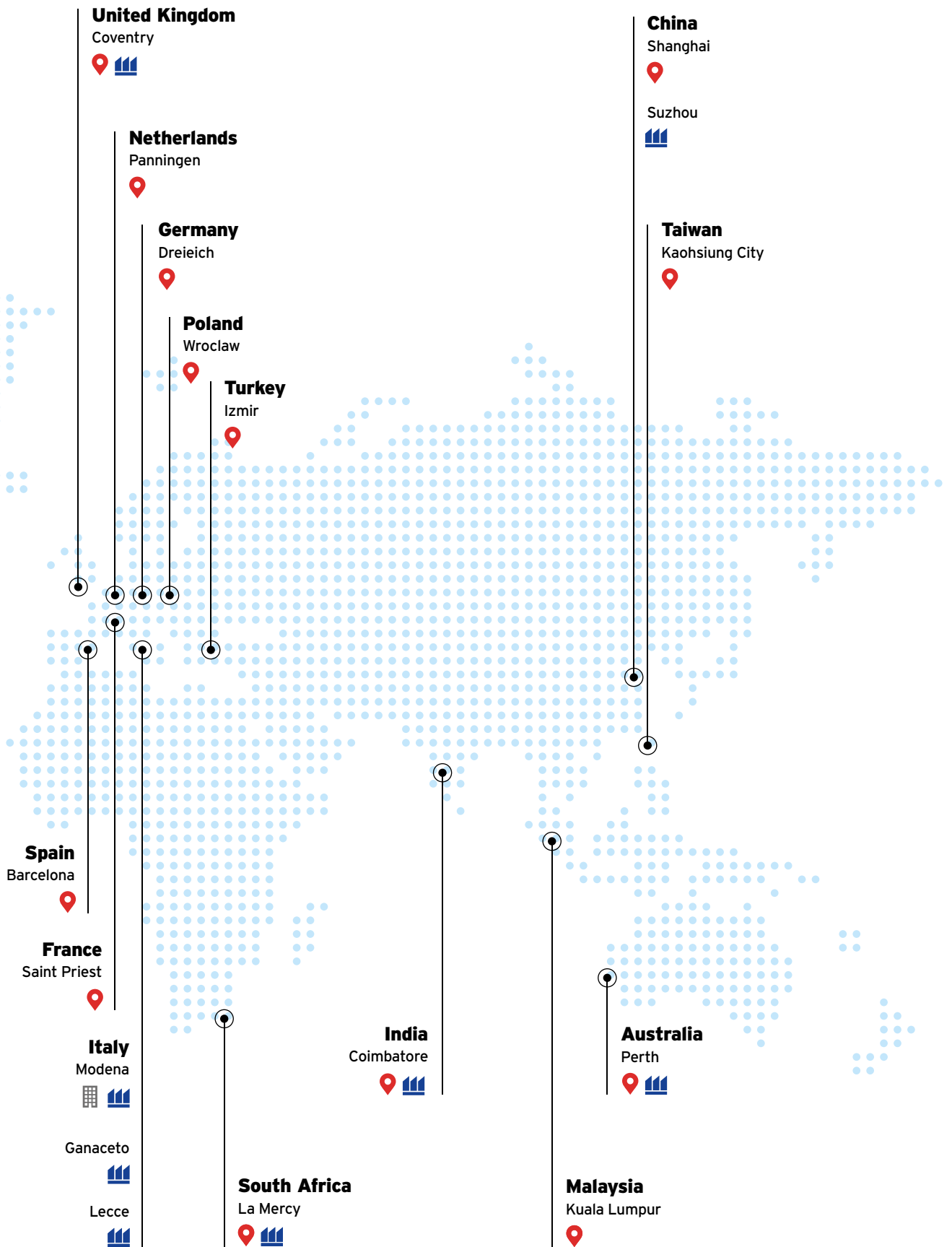

Product Range



Gear reducers and gearmotors

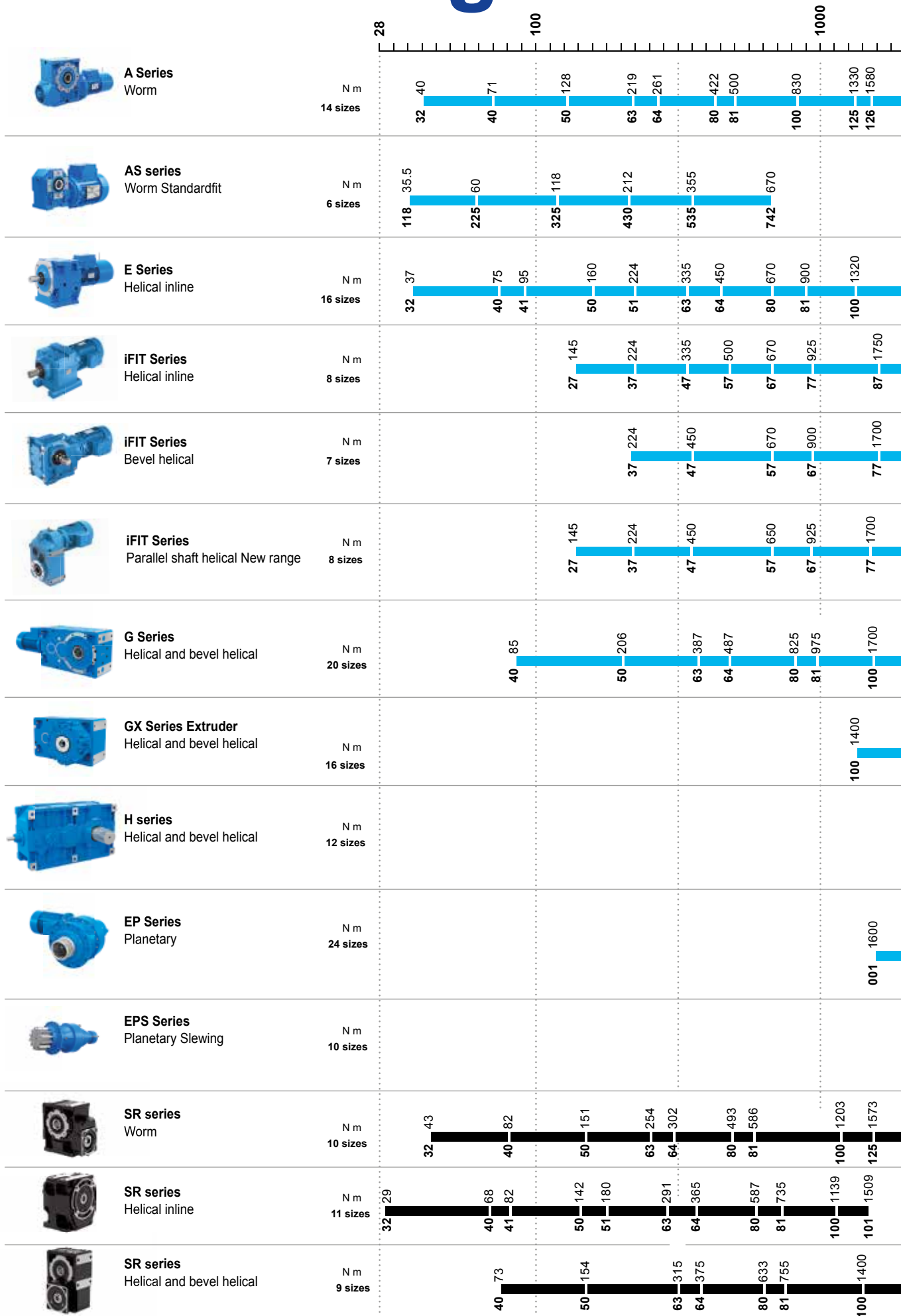





Rossi

Solutions for
an evolving
industry

Rossi S.p.A.
Via Emilia Ovest 915/A
41123 Modena - Italy

info@rossi.com
www.rossi.com

2638.CAT. EPS.24.07-0-EN

© Rossi S.p.A. Rossi reserves the right to make any modification whenever to this publication contents. The information given in this document only contains general descriptions and/or performance features which may not always specifically reflect those described.

The Customer is responsible for the correct selection and application of product in view of its industrial and/or commercial needs, unless the use has been recommended by technical qualified personnel of Rossi, who were duly informed about Customer's application purposes. In this case all the necessary data required for the selection shall be communicated exactly and in writing by the Customer, stated in the order and confirmed by Rossi. The Customer is always responsible for the safety of product applications. Every care has been taken in the drawing up of the catalog to ensure the accuracy of the information contained in this publication, however Rossi can accept no responsibility for any errors, omissions or outdated data. Due to the constant evolution of the state of the art, Rossi reserves the right to make any modification whenever to this publication contents. The responsibility for the product selection is of the Customer, excluding different agreements duly legalized in writing and undersigned by the Parties.